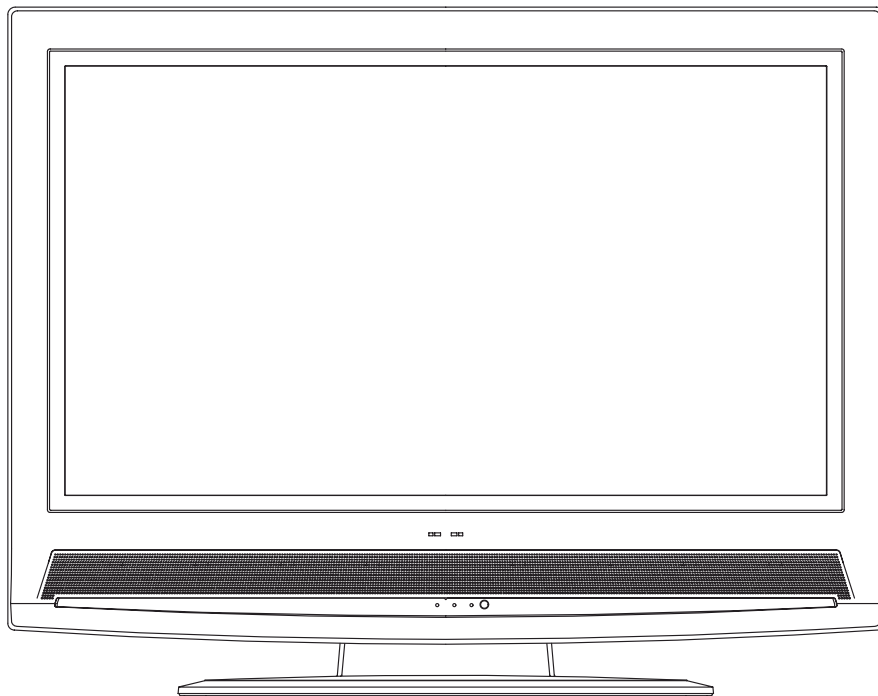


***SYLVANIA***

# **SERVICE MANUAL**

**32" COLOR LCD TELEVISION**

**6632LCT/6632LG**



# IMPORTANT SAFETY NOTICE

Proper service and repair is important to the safe, reliable operation of all Funai Equipment. The service procedures recommended by Funai and described in this service manual are effective methods of performing service operations. Some of these service special tools should be used when and as recommended.

It is important to note that this service manual contains various CAUTIONS and NOTICES which should be carefully read in order to minimize the risk of personal injury to service personnel. The possibility exists that improper service methods may damage the equipment. It also is important to understand that these CAUTIONS and NOTICES ARE NOT EXHAUSTIVE. Funai could not possibly know, evaluate and advice the service trade of all conceivable ways in which service might be done or of the possible hazardous consequences of each way. Consequently, Funai has not undertaken any such broad evaluation. Accordingly, a servicer who uses a service procedure or tool which is not recommended by Funai must first use all precautions thoroughly so that neither his safety nor the safe operation of the equipment will be jeopardized by the service method selected.

## TABLE OF CONTENTS

Specifications . . . . .	1-1
Important Safety Precautions . . . . .	2-1
Standard Notes for Servicing . . . . .	3-1
Cabinet Disassembly Instructions . . . . .	4-1
Electrical Adjustment Instructions . . . . .	5-1
How to initialize the LCD Television . . . . .	6-1
Block Diagrams . . . . .	7-1
Schematic Diagrams / CBA's and Test Points . . . . .	8-1
Waveforms . . . . .	9-1
Wiring Diagram . . . . .	10-1
Exploded Views . . . . .	11-1
Mechanical Parts List . . . . .	12-1
Electrical Parts List . . . . .	13-1

**The LCD panel is manufactured to provide many years of useful life. Occasionally a few non active pixels may appear as a tiny spec of color. This is not to be considered a defect in the LCD screen.**

# SPECIFICATIONS

## < TUNER >

ANT. Input ----- 75 ohm Unbal., F type  
 Reference Level----- 20 Vp-p (LCD Green Cathode)  
 Test Input Signal ----- 400 Hz 30% modulation

Description	Condition	Unit	Nominal	Limit
1. Intermediate Freq.	Picture Sound	MHz	45.75	---
		MHz	41.25	---
2. Color Killer Sens.	CH-2	dB $\mu$ V	17	23
	CH-10	dB $\mu$ V	17	23
	CH-55	dB $\mu$ V	17	23
3. AFT Pull In Range (10 mV input)	---	MHz	$\pm$ 2.4	$\pm$ 2.1

## < LCD PANEL >

Description	Condition	Unit	Nominal	Limit
1. Number of Pixels	Horizontal Vertical	pixels	1280x 3	---
		pixels	720	---
2. Brightness		cd/m <sup>2</sup>	550	---
3. Response Time (tr+tf)	---	msec	25	---
4. Support Color	---	-	16.7 mil. (8 bit)	---
5. Viewing Angle	Horizontal Vertical	°	-85 to 85	---
		°	-85 to 85	---

## < VIDEO >

Description	Condition	Unit	Nominal	Limit
1. Over Scan	Horizontal Vertical	%	5	---
		%	5	---
2. Color Temperature	---		12000	---
	x	°K	0.272	$\pm$ 0.03
	y		0.278	$\pm$ 0.03
3. Resolution	Horizontal Vertical	line	400	---
		line	350	---

## < AUDIO >

All items are measured across 8  $\Omega$  load at speaker output terminal with L.P.F.

Description	Condition	Unit	Nominal	Limit
1. Audio Output Power	10% THD: Lch/Rch	W	5.0/5.0	4.5/4.5
2. Audio Distortion	500mW: Lch/Rch	%	1.0/1.0	4.0/4.0
3. Audio Freq. Response	-6dB: Lch -6dB: Rch	Hz	100 to 10 k	---
		Hz	100 to 10 k	---

**Note:** Nominal specifications represent the design specifications. All units should be able to approximate these. Some will exceed and some may drop slightly below these specifications. Limit specifications represent the absolute worst condition that still might be considered acceptable. In no case should a unit fail to meet limit specifications.

# IMPORTANT SAFETY PRECAUTIONS

Prior to shipment from the factory, our products are strictly inspected for recognized product safety and electrical codes of the countries in which they are to be sold. However, in order to maintain such compliance, it is equally important to implement the following precautions when a set is being serviced.

## Safety Precautions for LCD TV Circuit

### 1. Before returning an instrument to the

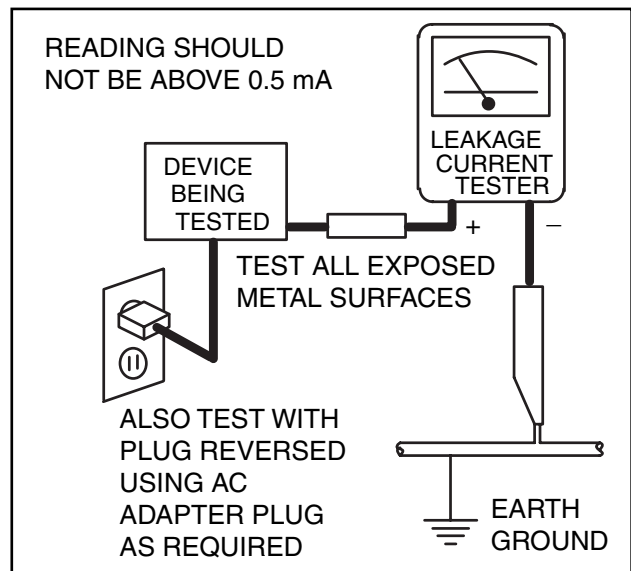
**customer**, always make a safety check of the entire instrument, including, but not limited to, the following items:

**a.** Be sure that no built-in protective devices are defective and have been defeated during servicing. (1) Protective shields are provided on this chassis to protect both the technician and the customer. Correctly replace all missing protective shields, including any removed for servicing convenience. (2) When reinstalling the chassis and/or other assembly in the cabinet, be sure to put back in place all protective devices, including but not limited to, nonmetallic control knobs, insulating fishpapers, adjustment and compartment covers/shields, and isolation resistor/capacitor networks. **Do not operate this instrument or permit it to be operated without all protective devices correctly installed and functioning. Servicers who defeat safety features or fail to perform safety checks may be liable for any resulting damage.**

**b.** Be sure that there are no cabinet openings through which an adult or child might be able to insert their fingers and contact a hazardous voltage. Such openings include, but are not limited to, (1) spacing between the Liquid Crystal Panel and the cabinet mask, (2) excessively wide cabinet ventilation slots, and (3) an improperly fitted and/or incorrectly secured cabinet back cover.


**c. Antenna Cold Check** - With the instrument AC plug removed from any AC source, connect an electrical jumper across the two AC plug prongs. Place the instrument AC switch in the on position. Connect one lead of an ohmmeter to the AC plug prongs tied together and touch the other ohmmeter lead in turn to each tuner antenna input exposed terminal screw and, if applicable, to the coaxial connector. If the measured resistance is less than 1.0 megohm or greater than 5.2 megohm, an abnormality exists that must be corrected before the instrument is returned to the customer. Repeat this test with the instrument AC switch in the off position.

**d. Leakage Current Hot Check** - With the instrument completely reassembled, plug the AC line cord directly into a 120 V AC outlet. (Do not use an isolation transformer during this test.) Use a leakage current tester or a metering system that complies with American National Standards Institute (ANSI) C101.1 Leakage Current for Appliances and Underwriters Laboratories (UL) 1410, (50.7). With the instrument AC switch first in the on position and then in the off position, measure from a known earth ground (metal water pipe, conduit, etc.) to all exposed metal parts of the instrument (antennas, handle brackets, metal cabinet, screw heads, metallic overlays, control shafts, etc.), especially any exposed metal parts that offer an electrical return path to the chassis. Any current measured must not exceed 0.5 milli-ampere. Reverse the instrument power cord plug in the outlet and repeat the test.



**ANY MEASUREMENTS NOT WITHIN THE LIMITS SPECIFIED HEREIN INDICATE A POTENTIAL SHOCK HAZARD THAT MUST BE ELIMINATED BEFORE RETURNING THE INSTRUMENT TO THE CUSTOMER OR BEFORE CONNECTING THE ANTENNA OR ACCESSORIES.**

**2.** Read and comply with all caution and safety-related notes on or inside the receiver cabinet, on the receiver chassis, or on the Liquid Crystal Panel.

- 3. Design Alteration Warning** - Do not alter or add to the mechanical or electrical design of this TV receiver. Design alterations and additions, including, but not limited to circuit modifications and the addition of items such as auxiliary audio and/or video output connections, might alter the safety characteristics of this receiver and create a hazard to the user. Any design alterations or additions will void the manufacturer's warranty and may make you, the servicer, responsible for personal injury or property damage resulting therefrom.
- 4. Hot Chassis Warning** -
  - a. Some TV receiver chassis are electrically connected directly to one conductor of the AC power cord and maybe safety-serviced without an isolation transformer only if the AC power plug is inserted so that the chassis is connected to the ground side of the AC power source. To confirm that the AC power plug is inserted correctly, with an AC voltmeter, measure between the chassis and a known earth ground. If a voltage reading in excess of 1.0V is obtained, remove and reinsert the AC power plug in the opposite polarity and again measure the voltage potential between the chassis and a known earth ground.
  - b. Some TV receiver chassis normally have 85V AC(RMS) between chassis and earth ground regardless of the AC plug polarity. This chassis can be safety-serviced only with an isolation transformer inserted in the power line between the receiver and the AC power source, for both personnel and test equipment protection.
  - c. Some TV receiver chassis have a secondary ground system in addition to the main chassis ground. This secondary ground system is not isolated from the AC power line. The two ground systems are electrically separated by insulation material that must not be defeated or altered.
- 5.** Observe original lead dress. Take extra care to assure correct lead dress in the following areas: a. near sharp edges, b. near thermally hot parts-be sure that leads and components do not touch thermally hot parts, c. the AC supply, d. high voltage, and, e. antenna wiring. Always inspect in all areas for pinched, out of place, or frayed wiring. Check AC power cord for damage.
- 6.** Components, parts, and/or wiring that appear to have overheated or are otherwise damaged should be replaced with components, parts, or wiring that meet original specifications. Additionally, determine the cause of overheating and/or damage and, if necessary, take corrective action to remove any potential safety hazard.
- 7. Product Safety Notice** - Some electrical and mechanical parts have special safety-related characteristics which are often not evident from visual inspection, nor can the protection they give necessarily be obtained by replacing them with components rated for higher voltage, wattage, etc. Parts that have special safety characteristics are identified by a  on schematics and in parts lists. Use of a substitute replacement that does not have the same safety characteristics as the recommended replacement part might create shock, fire, and/or other hazards. The product's safety is under review continuously and new instructions are issued whenever appropriate. Prior to shipment from the factory, our products are strictly inspected to confirm they comply with the recognized product safety and electrical codes of the countries in which they are to be sold. However, in order to maintain such compliance, it is equally important to implement the following precautions when a set is being serviced.

## Precautions during Servicing

- A.** Parts identified by the **▲** symbol are critical for safety.  
Replace only with part number specified.
- B.** In addition to safety, other parts and assemblies are specified for conformance with regulations applying to spurious radiation. These must also be replaced only with specified replacements.  
Examples: RF converters, RF cables, noise blocking capacitors, and noise blocking filters, etc.
- C.** Use specified internal wiring. Note especially:
  - 1) Wires covered with PVC tubing
  - 2) Double insulated wires
  - 3) High voltage leads
- D.** Use specified insulating materials for hazardous live parts. Note especially:
  - 1) Insulation Tape
  - 2) PVC tubing
  - 3) Spacers
  - 4) Insulators for transistors.
- E.** When replacing AC primary side components (transformers, power cord, etc.), wrap ends of wires securely about the terminals before soldering.
- F.** Observe that the wires do not contact heat producing parts (heat sinks, oxide metal film resistors, fusible resistors, etc.)
- G.** Check that replaced wires do not contact sharp edged or pointed parts.
- H.** When a power cord has been replaced, check that 5~6 kg of force in any direction will not loosen it.
- I.** Also check areas surrounding repaired locations.
- J.** Use care that foreign objects (screws, solder droplets, etc.) do not remain inside the set.
- K.** Crimp type wire connector  
The power transformer uses crimp type connectors which connect the power cord and the primary side of the transformer. When replacing the transformer, follow these steps carefully and precisely to prevent shock hazards.  
Replacement procedure
  - 1) Remove the old connector by cutting the wires at a point close to the connector.  
Important: Do not re-use a connector (discard it).
  - 2) Strip about 15 mm of the insulation from the ends of the wires. If the wires are stranded, twist the strands to avoid frayed conductors.
  - 3) Align the lengths of the wires to be connected. Insert the wires fully into the connector.
  - 4) Use the crimping tool to crimp the metal sleeve at the center position. Be sure to crimp fully to the complete closure of the tool.
- L.** When connecting or disconnecting the internal connectors, first, disconnect the AC plug from the AC supply outlet.
- M.** When installing parts or assembling the cabinet parts, be sure to use the proper screws and tighten certainly.

## Safety Check after Servicing

Examine the area surrounding the repaired location for damage or deterioration. Observe that screws, parts and wires have been returned to original positions. Afterwards, perform the following tests and confirm the specified values in order to verify compliance with safety standards.

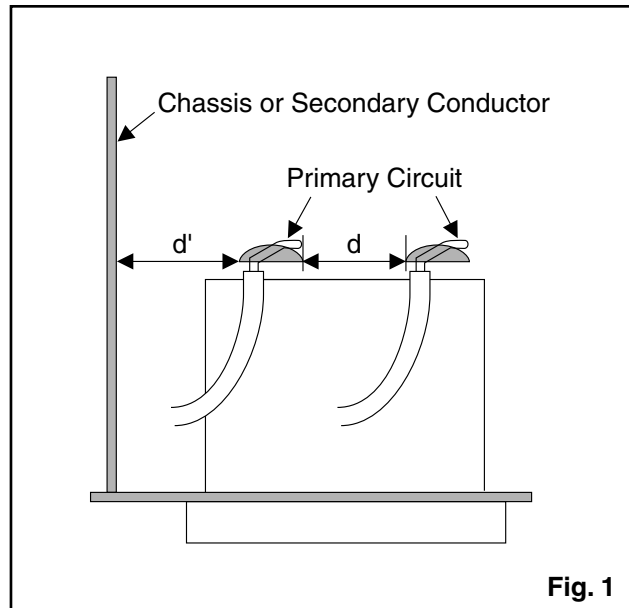
### 1. Clearance Distance

When replacing primary circuit components, confirm specified clearance distance ( $d$ ) and ( $d'$ ) between soldered terminals, and between terminals and surrounding metallic parts. (See Fig. 1)

**Table 1: Ratings for selected area**

AC Line Voltage	Region	Clearance Distance ( $d$ ), ( $d'$ )
110 to 130 V	U.S.A. or Canada	$\geq 3.2$ mm (0.126 inches)

**Note:** This table is unofficial and for reference only. Be sure to confirm the precise values.

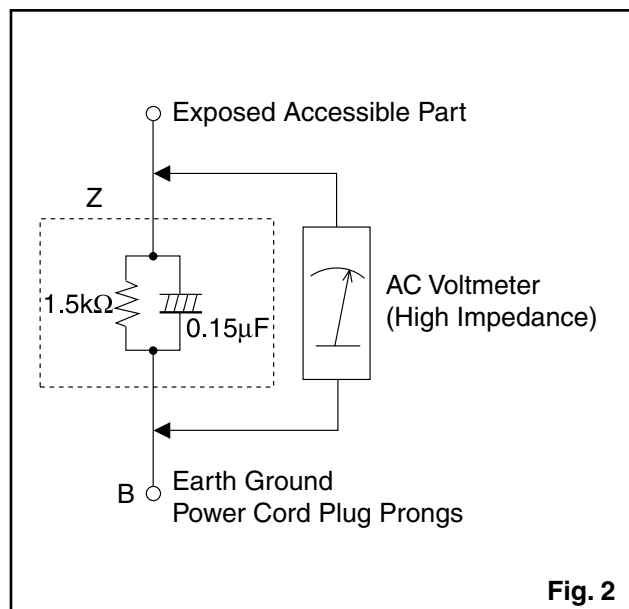


### 2. Leakage Current Test

Confirm the specified (or lower) leakage current between B (earth ground, power cord plug prongs) and externally exposed accessible parts (RF terminals, antenna terminals, video and audio input and output terminals, microphone jacks, earphone jacks, etc.) is lower than or equal to the specified value in the table below.

#### Measuring Method: (Power ON)

Insert load Z between B (earth ground, power cord plug prongs) and exposed accessible parts. Use an AC voltmeter to measure across both terminals of load Z. See Fig. 2 and following table.



**Fig. 2**

**Table 2: Leakage current ratings for selected areas**

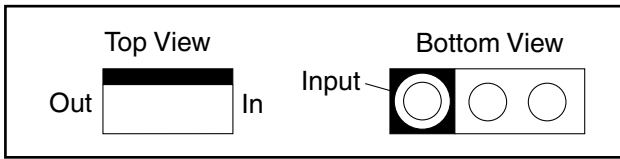
AC Line Voltage	Region	Load Z	Leakage Current ( $i$ )	Earth Ground (B) to:
110 to 130 V	U.S.A. or Canada	0.15 $\mu$ F CAP. & 1.5 k $\Omega$ RES. Connected in parallel	$i \leq 0.5$ mA rms	Exposed accessible parts

**Note:** This table is unofficial and for reference only. Be sure to confirm the precise values.

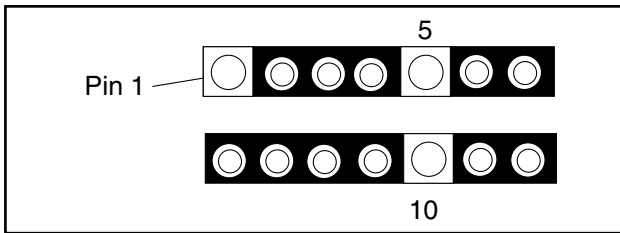
# STANDARD NOTES FOR SERVICING

## Circuit Board Indications

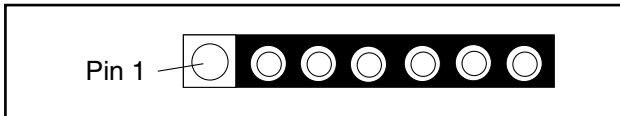
1. The output pin of the 3 pin Regulator ICs is indicated as shown.



2. For other ICs, pin 1 and every fifth pin are indicated as shown.

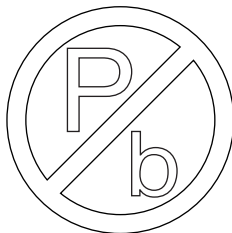


3. The 1st pin of every male connector is indicated as shown.



## Pb (Lead) Free Solder

**Pb free mark will be found on PCBs which use Pb free solder. (Refer to figure.) For PCBs with Pb free mark, be sure to use Pb free solder. For PCBs without Pb free mark, use standard solder.**



Pb free mark

## How to Remove / Install Flat Pack-IC

### 1. Removal

**With Hot-Air Flat Pack-IC Desoldering Machine:**

1. Prepare the hot-air flat pack-IC desoldering machine, then apply hot air to the Flat Pack-IC (about 5 to 6 seconds). (Fig. S-1-1)

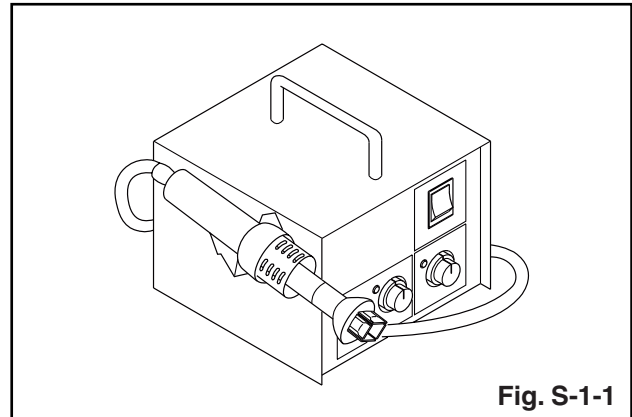


Fig. S-1-1

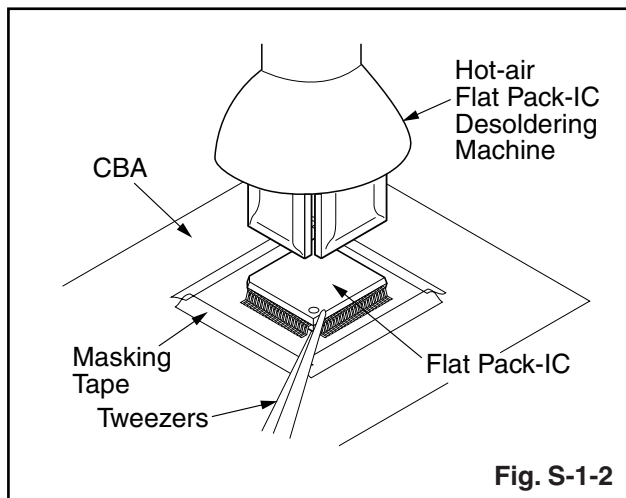
2. Remove the flat pack-IC with tweezers while applying the hot air.
3. Bottom of the flat pack-IC is fixed with glue to the CBA; when removing entire flat pack-IC, first apply soldering iron to center of the flat pack-IC and heat up. Then remove (glue will be melted). (Fig. S-1-6)
4. Release the flat pack-IC from the CBA using tweezers. (Fig. S-1-6)

### CAUTION:

1. The Flat Pack-IC shape may differ by models. Use an appropriate hot-air flat pack-IC desoldering machine, whose shape matches that of the Flat Pack-IC.
2. Do not supply hot air to the chip parts around the flat pack-IC for over 6 seconds because damage to the chip parts may occur. Put masking tape around the flat pack-IC to protect other parts from damage. (Fig. S-1-2)

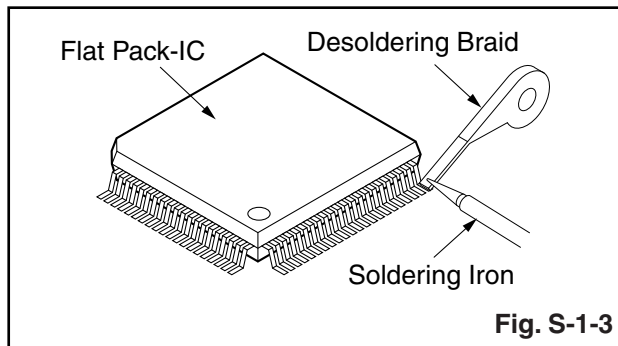


3. The flat pack-IC on the CBA is affixed with glue, so be careful not to break or damage the foil of each pin or the solder lands under the IC when removing it.

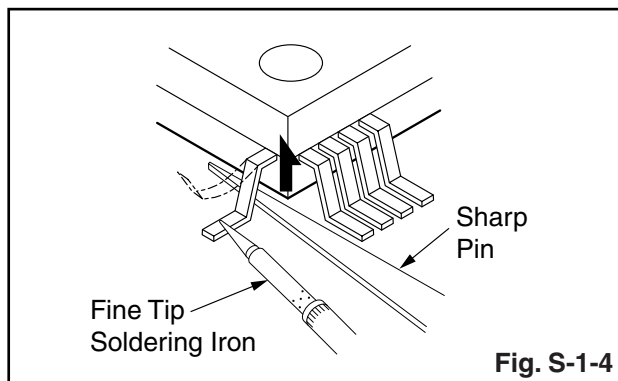


#### With Soldering Iron:

1. Using desoldering braid, remove the solder from all pins of the flat pack-IC. When you use solder flux which is applied to all pins of the flat pack-IC, you can remove it easily. (Fig. S-1-3)



2. Lift each lead of the flat pack-IC upward one by one, using a sharp pin or wire to which solder will not adhere (iron wire). When heating the pins, use a fine tip soldering iron or a hot air desoldering machine. (Fig. S-1-4)

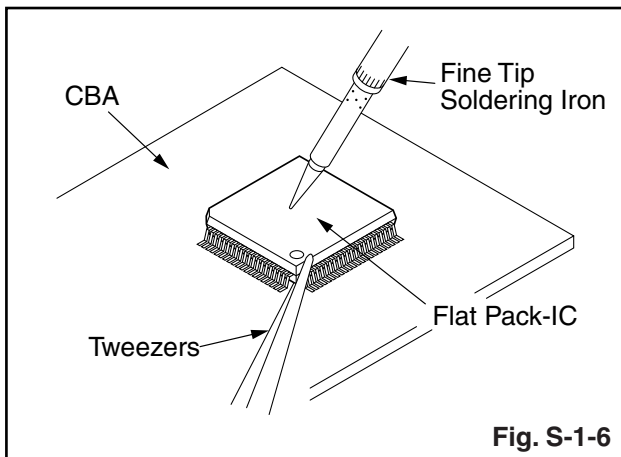
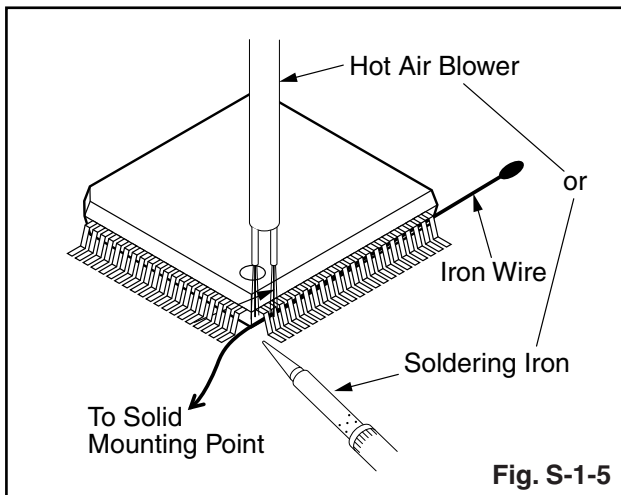


3. Bottom of the flat pack-IC is fixed with glue to the CBA; when removing entire flat pack-IC, first apply soldering iron to center of the flat pack-IC and heat up. Then remove (glue will be melted). (Fig. S-1-6)
4. Release the flat pack-IC from the CBA using tweezers. (Fig. S-1-6)

### With Iron Wire:

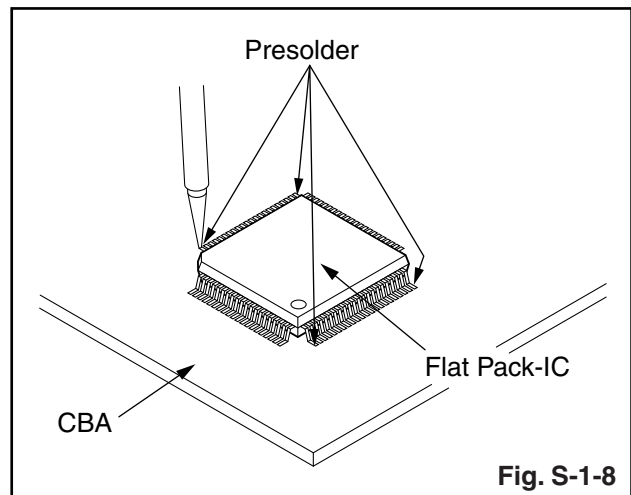
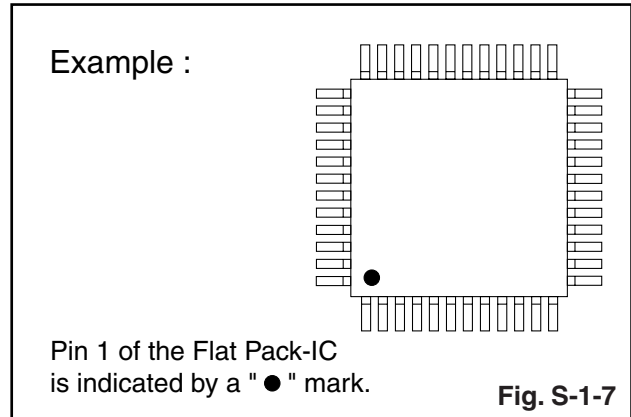
1. Using desoldering braid, remove the solder from all pins of the flat pack-IC. When you use solder flux which is applied to all pins of the flat pack-IC, you can remove it easily. (Fig. S-1-3)
2. Affix the wire to a workbench or solid mounting point, as shown in Fig. S-1-5.
3. While heating the pins using a fine tip soldering iron or hot air blower, pull up the wire as the solder melts so as to lift the IC leads from the CBA contact pads as shown in Fig. S-1-5.
4. Bottom of the flat pack-IC is fixed with glue to the CBA; when removing entire flat pack-IC, first apply soldering iron to center of the flat pack-IC and heat up. Then remove (glue will be melted). (Fig. S-1-6)
5. Release the flat pack-IC from the CBA using tweezers. (Fig. S-1-6)

**Note:** When using a soldering iron, care must be taken to ensure that the flat pack-IC is not being held by glue. When the flat pack-IC is removed from the CBA, handle it gently because it may be damaged if force is applied.



## 2. Installation

1. Using desoldering braid, remove the solder from the foil of each pin of the flat pack-IC on the CBA so you can install a replacement flat pack-IC more easily.
2. The "●" mark on the flat pack-IC indicates pin 1. (See Fig. S-1-7.) Be sure this mark matches the 1 on the PCB when positioning for installation. Then presolder the four corners of the flat pack-IC. (See Fig. S-1-8.)
3. Solder all pins of the flat pack-IC. Be sure that none of the pins have solder bridges.



# Instructions for Handling Semi-conductors

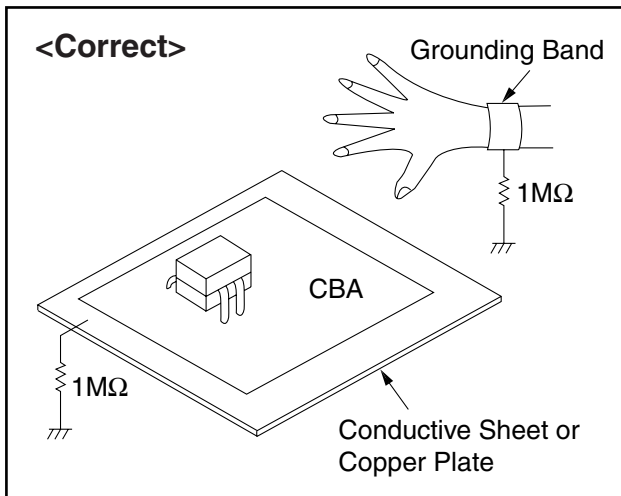
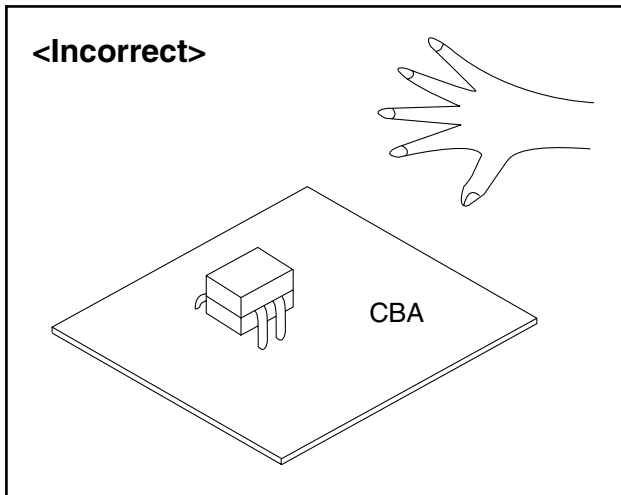
Electrostatic breakdown of the semi-conductors may occur due to a potential difference caused by electrostatic charge during unpacking or repair work.

## 1. Ground for Human Body

Be sure to wear a grounding band (1 M $\Omega$ ) that is properly grounded to remove any static electricity that may be charged on the body.

## 2. Ground for Workbench

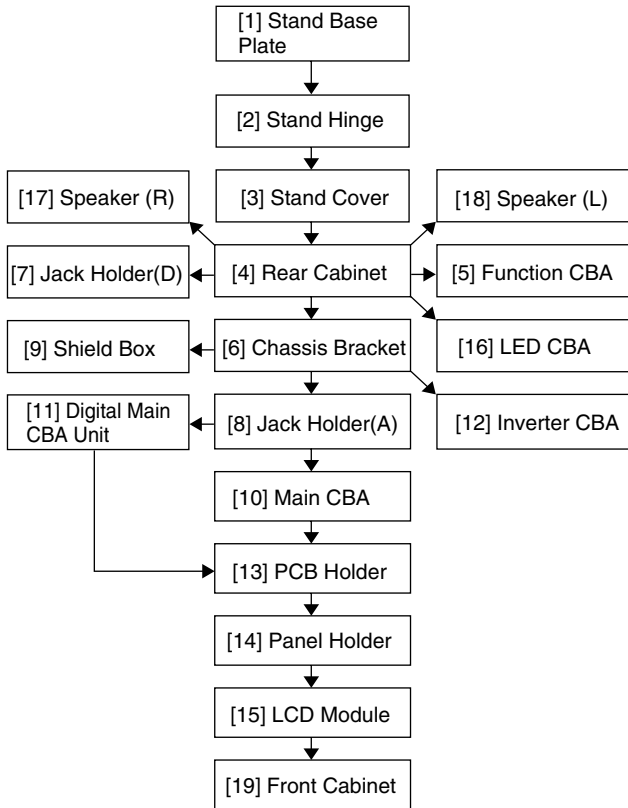
Be sure to place a conductive sheet or copper plate with proper grounding (1 M $\Omega$ ) on the workbench or other surface, where the semi-conductors are to be placed. Because the static electricity charge on clothing will not escape through the body grounding band, be careful to avoid contacting semi-conductors with your clothing.



# CABINET DISASSEMBLY INSTRUCTIONS

## 1. Disassembly Flowchart

This flowchart indicates the disassembly steps for the cabinet parts, and the CBA in order to gain access to item(s) to be serviced. When reassembling, follow the steps in reverse order. Bend, route and dress the cables as they were.



## 2. Disassembly Method

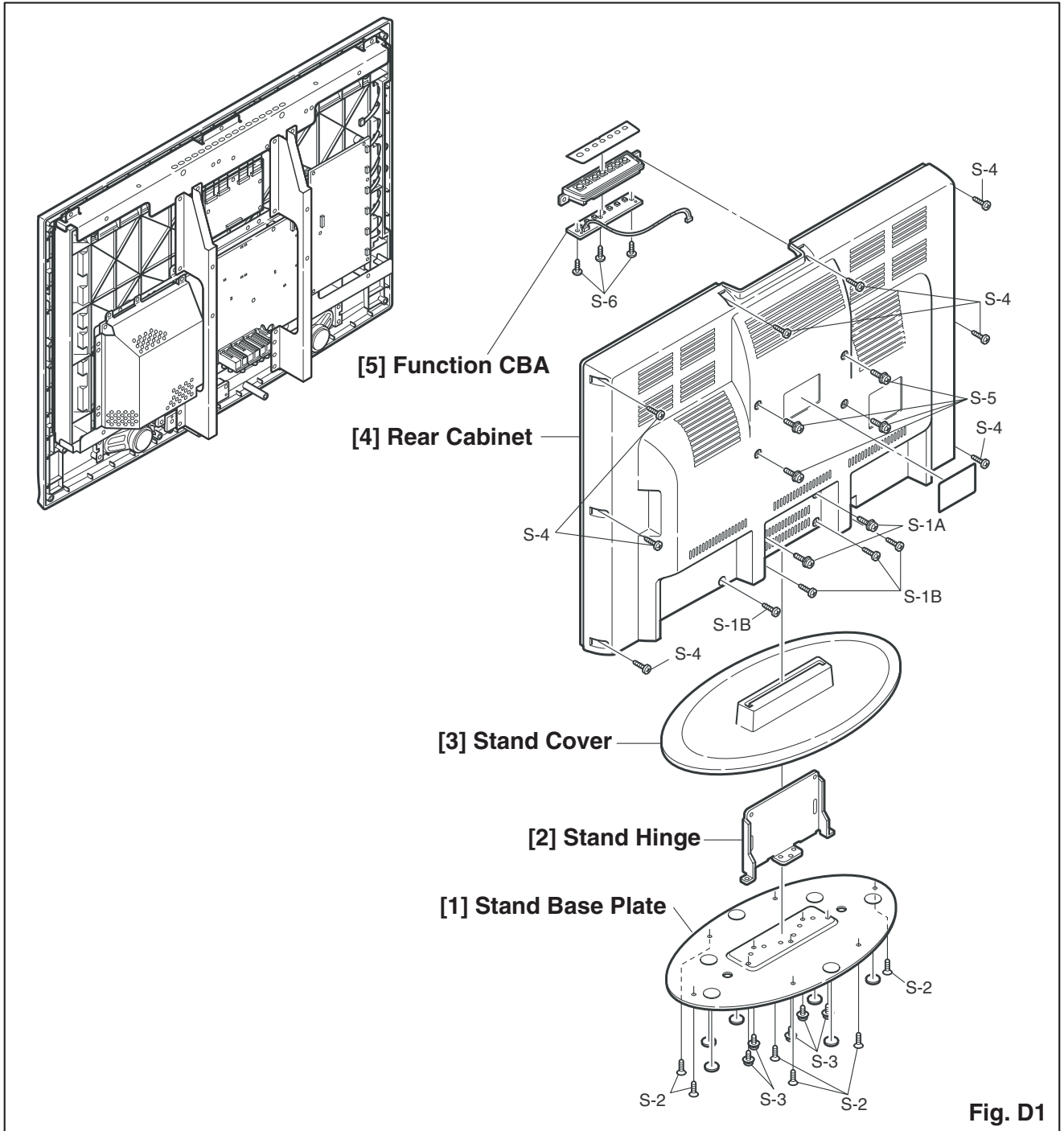
Step/ Loc. No.	Part	Removal		
		Fig. No.	Remove/*Unhook/ Unlock/Release/ Unplug/Unclamp/ Desolder	Note
[1]	Stand Base Plate	D1	2(S-1A), 4(S-1B), 6(S-2), 5(S-3)	---
[2]	Stand Hinge	D1	-----	---
[3]	Stand Cover	D1	-----	---
[4]	Rear Cabinet	D1	8(S-4), 4(S-5)	---
[5]	Function CBA	D1	3(S-6), *CN1505	---
[6]	Chassis Bracket	D2	10(S-7)	---
[7]	Jack Holder(D)	D2	(S-8)	---

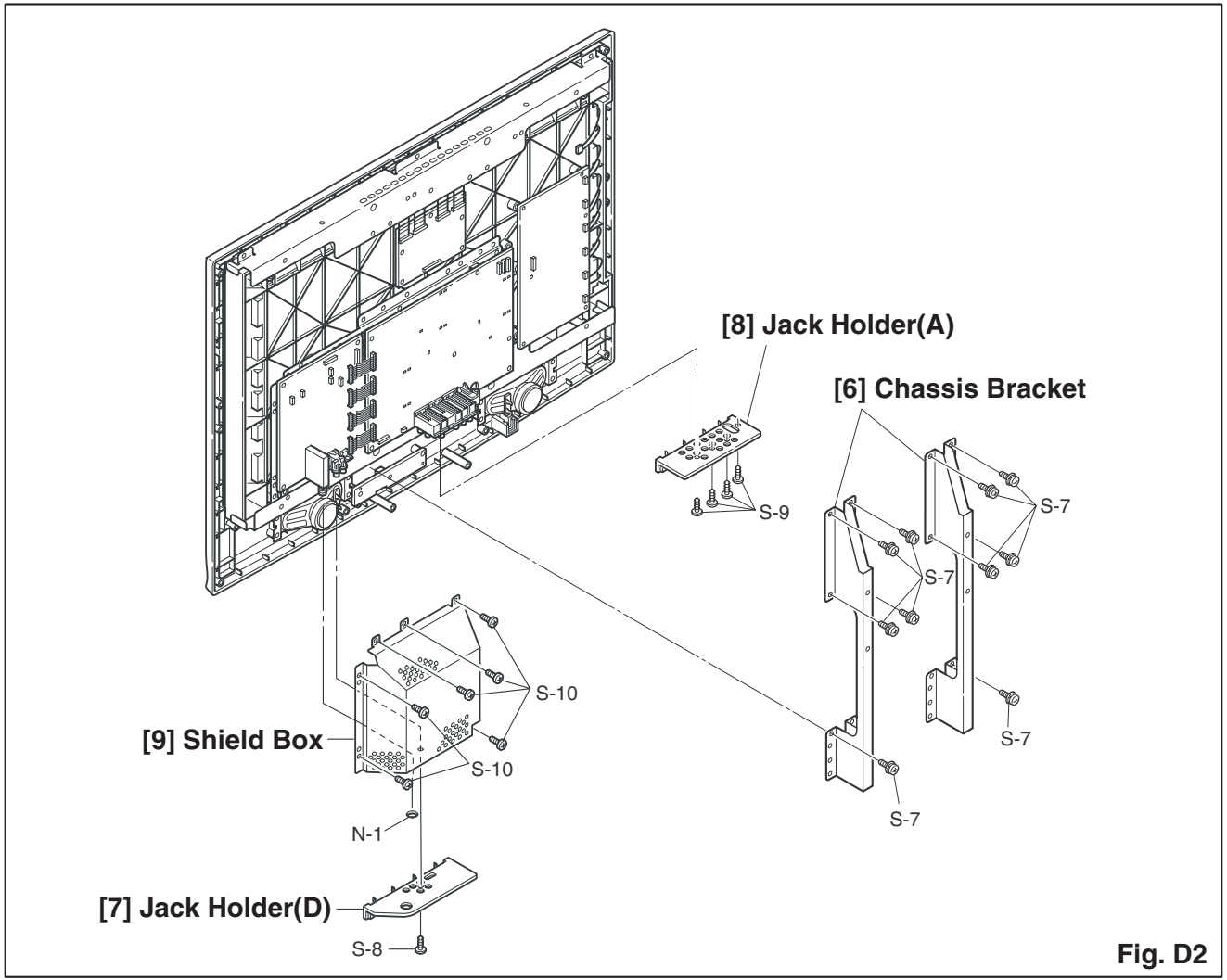
Step/ Loc. No.	Part	Removal		
		Fig. No.	Remove/*Unhook/ Unlock/Release/ Unplug/Unclamp/ Desolder	Note
[8]	Jack Holder(A)	D2	4(S-9)	---
[9]	Shield Box	D2	6(S-10), (N-1)	---
[10]	Main CBA	D3	4(S-11), *CN151, *CN253, *CN1111, *CN1112, *CN1113, *CN1116	---
[11]	Digital Main CBA Unit	D3	4(S-12), *CN1121	---
[12]	Inverter CBA	D3	6(S-13), *CN1050, *CN1100, *CN1150, *CN1150, *CN1200, *CN1250, CN1300	---
[13]	PCB Holder	D3	3(S-14), 2(S-15)	---
[14]	Panel Holder	D4	6(S-16), 5(S-17), 4(S-18)	---
[15]	LCD Module	D4	-----	---
[16]	LED CBA	D4	3(S-19), *CN803, *CN804	---
[17]	Speaker (R)	D4	4(S-20)	---
[18]	Speaker (L)	D4	4(S-21)	---
[19]	Front Cabinet	D4	-----	---

(1) (2) (3) (4) (5)

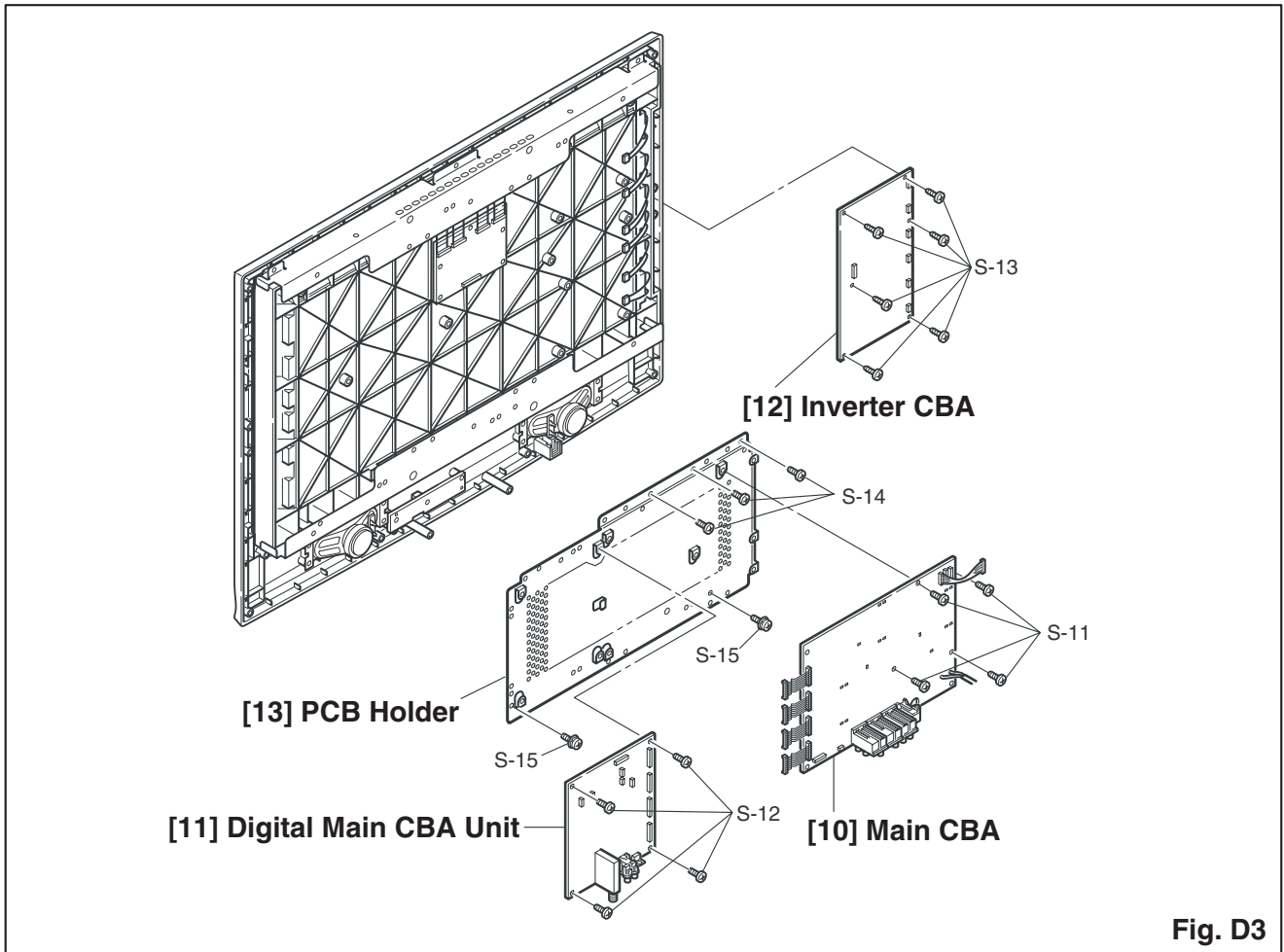
### Note:

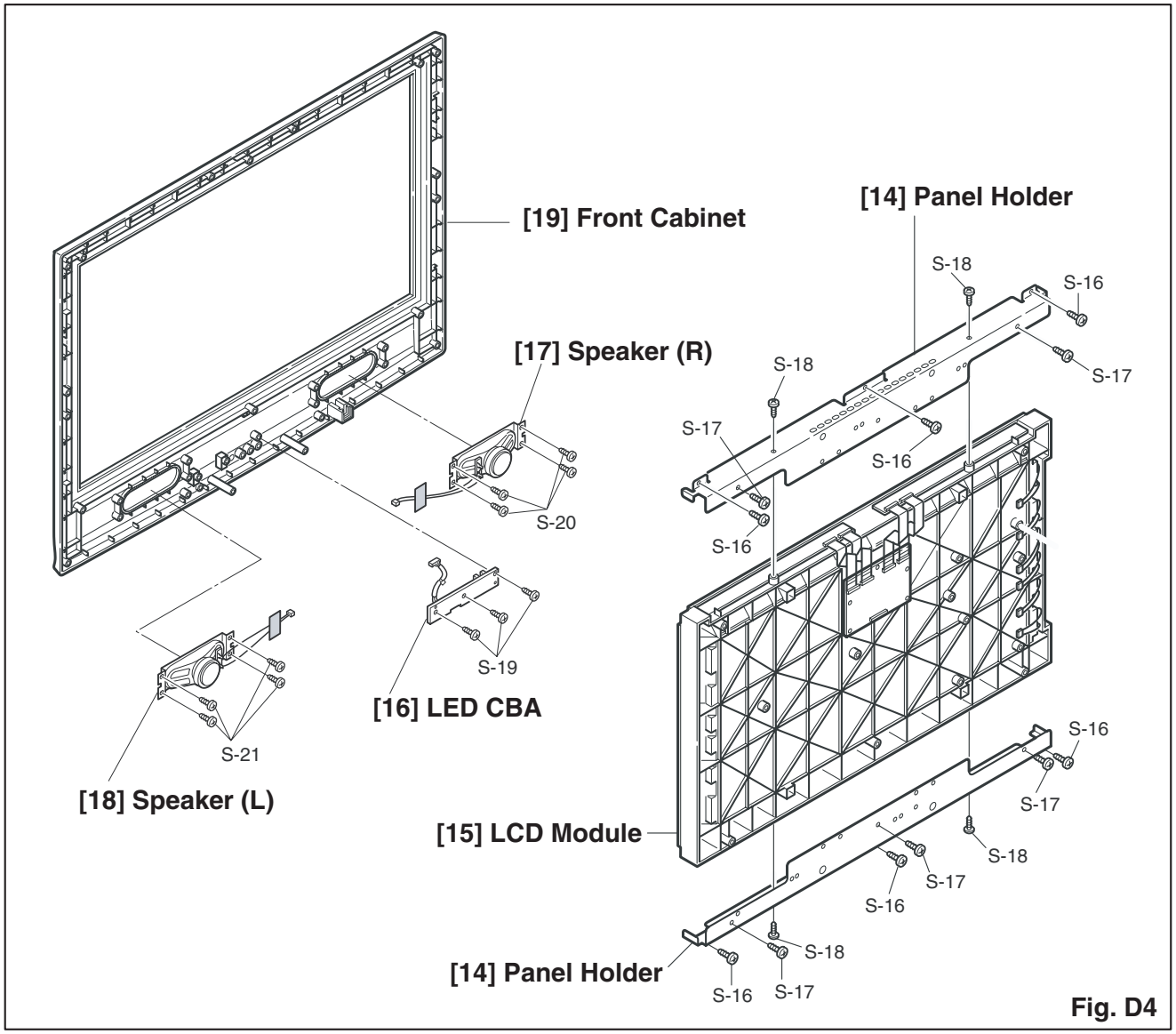
- Order of steps in procedure. When reassembling, follow the steps in reverse order. These numbers are also used as the Identification (location) No. of parts in figures.
- Parts to be removed or installed.
- Fig. No. showing procedure of part location
- Identification of parts to be removed, unhooked, unlocked, released, unplugged, unclamped, or desoldered.  
N = Nut, L = Locking Tab, S = Screw,  
CN = Connector  
\* = Unhook, Unlock, Release, Unplug, or Desolder  
e.g. 2(S-2) = two Screws (S-2),  
2(L-2) = two Locking Tabs (L-2)
- Refer to the following "Reference Notes in the Table."





**Fig. D2**

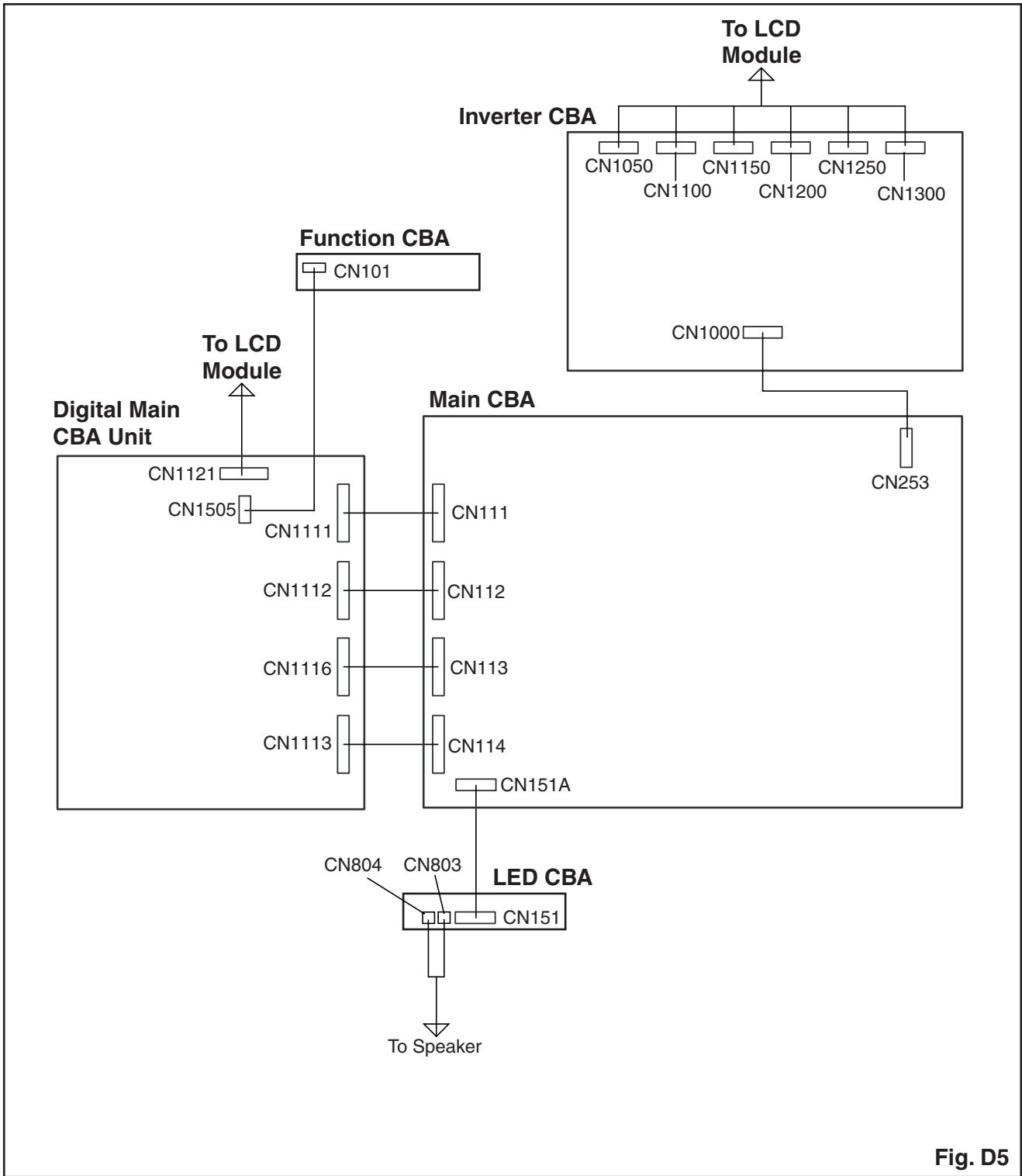




**Fig. D4**



# TV Cable Wiring Diagram



**Fig. D5**

# ELECTRICAL ADJUSTMENT INSTRUCTIONS

**General Note: “CBA” is abbreviation for “Circuit Board Assembly.”**

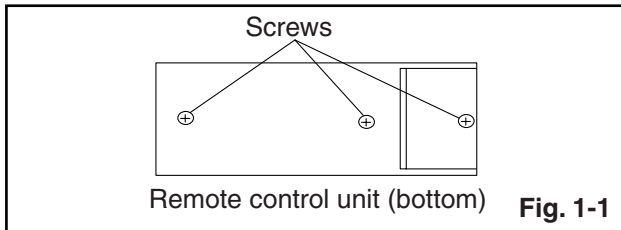
**Note:** Electrical adjustments are required after replacing circuit components and certain mechanical parts. It is important to perform these adjustments only after all repairs and replacements have been completed. Also, do not attempt these adjustments unless the proper equipment is available.

## Test Equipment Required

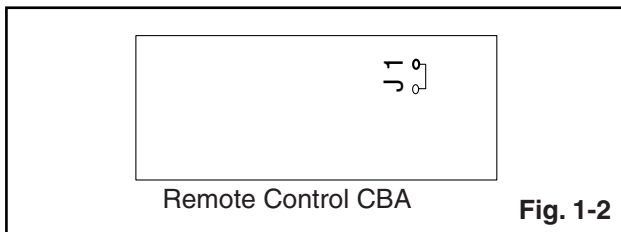
1. DC Voltmeter
2. NTSC Pattern Generator (Color Bar W/White Window, Red Color, Dot Pattern, Gray Scale, Monoscope, Multi-Burst)
3. Remote control unit: Part No. N0105UD or N0127UD
4. Color Analyzer

## How to make Service remote control unit:

1. Prepare normal remote control unit.  
(Part No. N0105UD or N0127UD)  
Remove 3 Screws from the back lid. (Fig. 1-1)



2. Add J1 (Jumper Wire) to the remote control CBA.  
(Fig. 1-2)

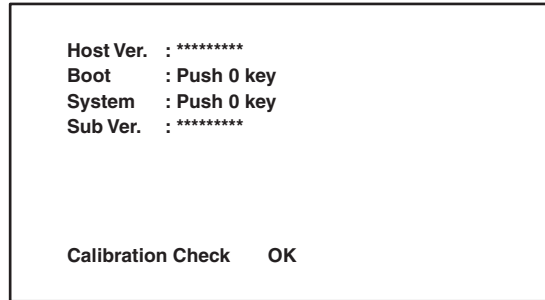


## How to set up the service mode:

### Service mode:

1. Use the service remote control unit.
2. Turn the power on. (Use main power on the TV unit.)
3. Press [SLEEP] button on the service remote control unit. The following screen appears.

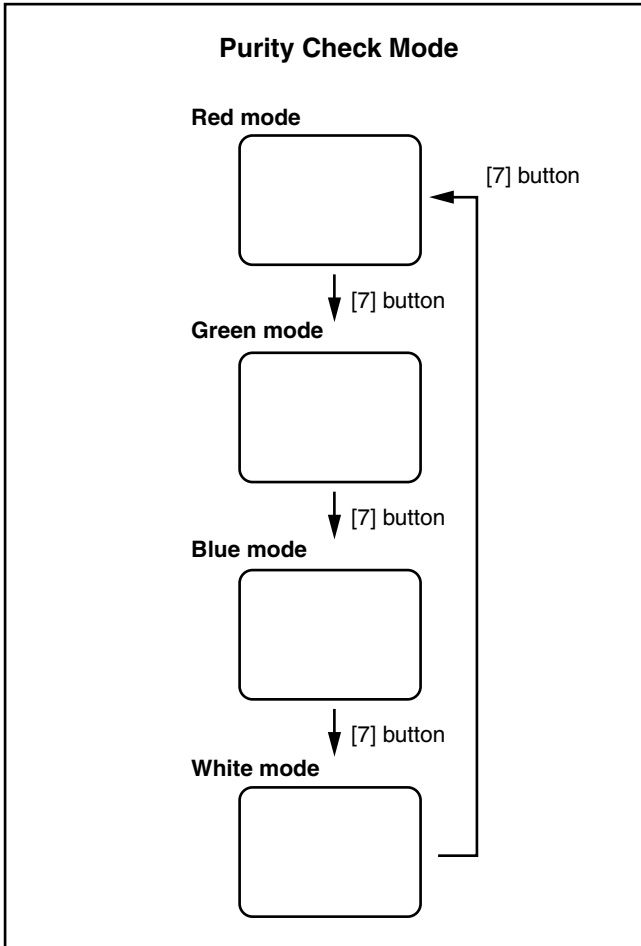
"\*" differs depending on the models.



# 1. Purity Check Mode

This mode cycles through full-screen displays of red, green, blue, and white to check for non-active pixels.

1. Enter the Service mode.
2. Each time pressing [7] button on the service remote control unit, the display changes as follows.



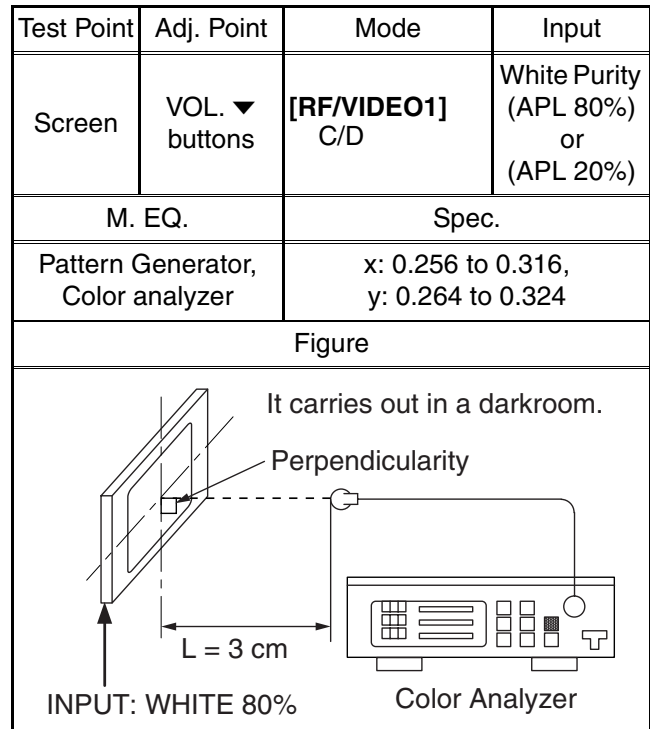
The following adjustment normally are not attempted in the field. Only when replacing the LCD Panel then adjust as a preparation.

# 2. White Balance Adjustment

\*This adjustment is needed when repairing T-CON CBA.

**Purpose:** To mix red, green and blue beams correctly for pure white.

**Symptom of Misadjustment:** White becomes bluish or reddish.



**Note:** Use service remote control unit

1. Operate the unit for more than 20 minutes.
2. Input the White Purity (APL 80% or APL 20%).
3. Set the color analyzer to the CHROMA mode and bring the optical receptor to the center on the LCD-Panel surface after zero point calibration as shown above.

**Note:** The optical receptor must be set perpendicularly to the LCD Panel surface.

4. Enter the Service mode. Press [VOL ▼] button on the remote control unit and select "C/D" mode.
5. When "x" value and "y" value are not within specification, adjust "DB (C/D)" or "DR (C/D)". Refer to "1. Initial Setting."

**Note:** "DB(C/D)" or "DR(C/D)" must be adjusted within  $\pm 0.01$ .

6. Turn the power off and on again. (Main power button on the TV unit.)

### 3. Auto Calibration

**Purpose:** To bring the color adjustment of each component into standard alignment.

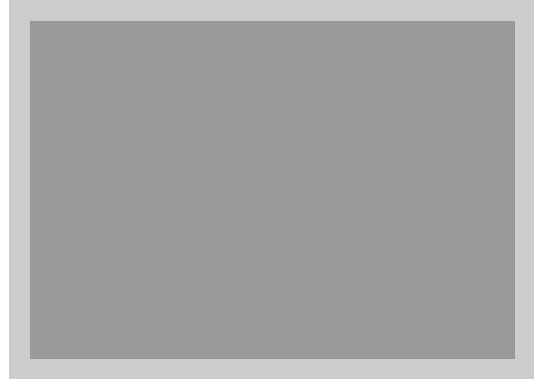
**Symptom of Misadjustment:** The color adjustment differs from component to component.

1. Input white raster signal (10%=10 IRE, 100%=100 IRE) from Component 1 Y jack.
2. Enter the service mode.
3. To enter the Auto Calibration adjustment mode, press [6] button on the service remote control unit.
4. To start auto adjustment, press [CH ▲] button on the service remote control unit.
  - In the auto adjustment mode, "Calibration Check" appears on the screen.
  - Upon completion, "Calibration Check OK" and "Push FCH UP key" appear on the screen.
  - If the auto adjustment failure, "Calibration Check NG" and "Push FCH UP key" appear on the screen.
5. Unplug AC cord and plug it in AC outlet again to reset then enter the service mode again.

### 4. Flicker Adjustment

\*This adjustment is needed when repairing T-CON CBA.

1. Enter the Service mode. (See page 5-1.)
2. Press [2] button on the remote control unit. The following screen appears.



3. If Flicker Adjustment is not fit, the screen become the following.



↑  
FLASH (Go and Off)

4. Turn the VR1 on the LCD Module so that flash stops.

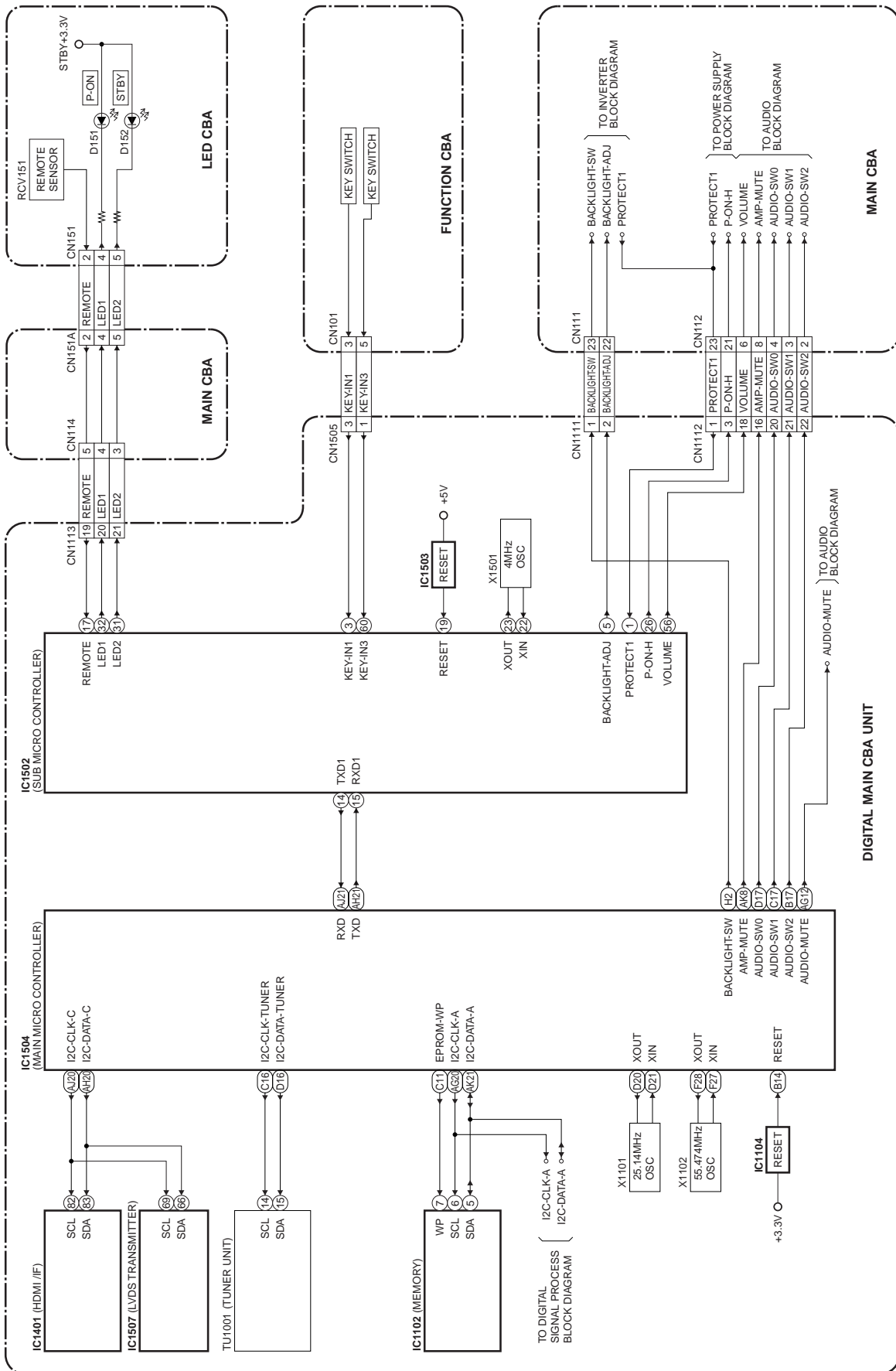
# HOW TO INITIALIZE THE LCD TELEVISION

## How to initialize the LCD television:

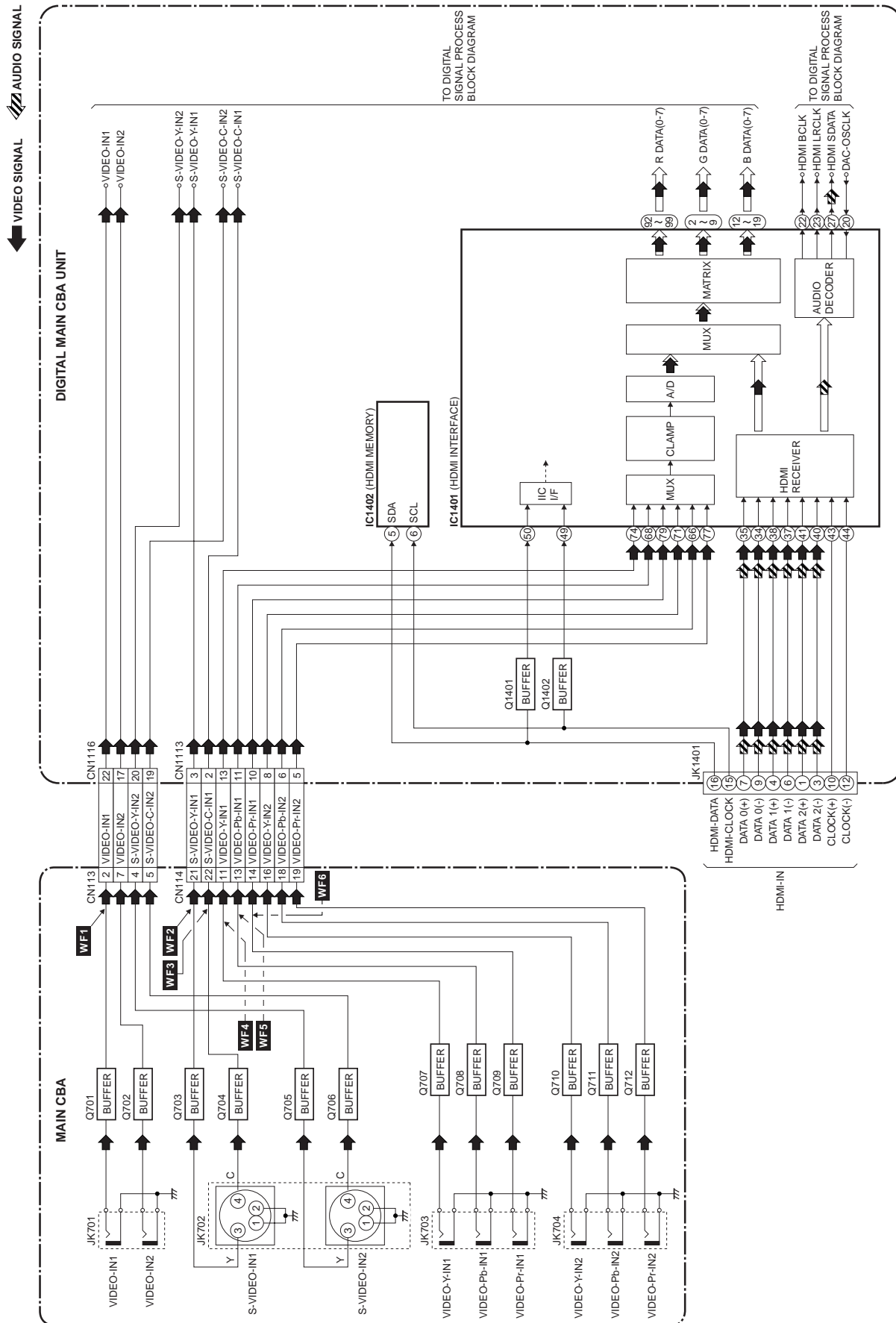
1. To turn the power on, press [POWER] button on the normal remote control unit or the unit.
2. Use the service remote control unit. (Refer to "ELECTRICAL ADJUSTMENT INSTRUCTIONS" section.
3. To enter the service mode, press [SLEEP] button on the service remote control unit.
  - To cancel the service mode, press [TV POWER] button on the remote control.
4. To initialize the LCD television, press [DISPLAY] button on the normal remote control unit.
  - "INITIALIZED" (red) appears on the screen.
  - After few seconds (completion initialization), the screen is reset.

# BLOCK DIAGRAMS

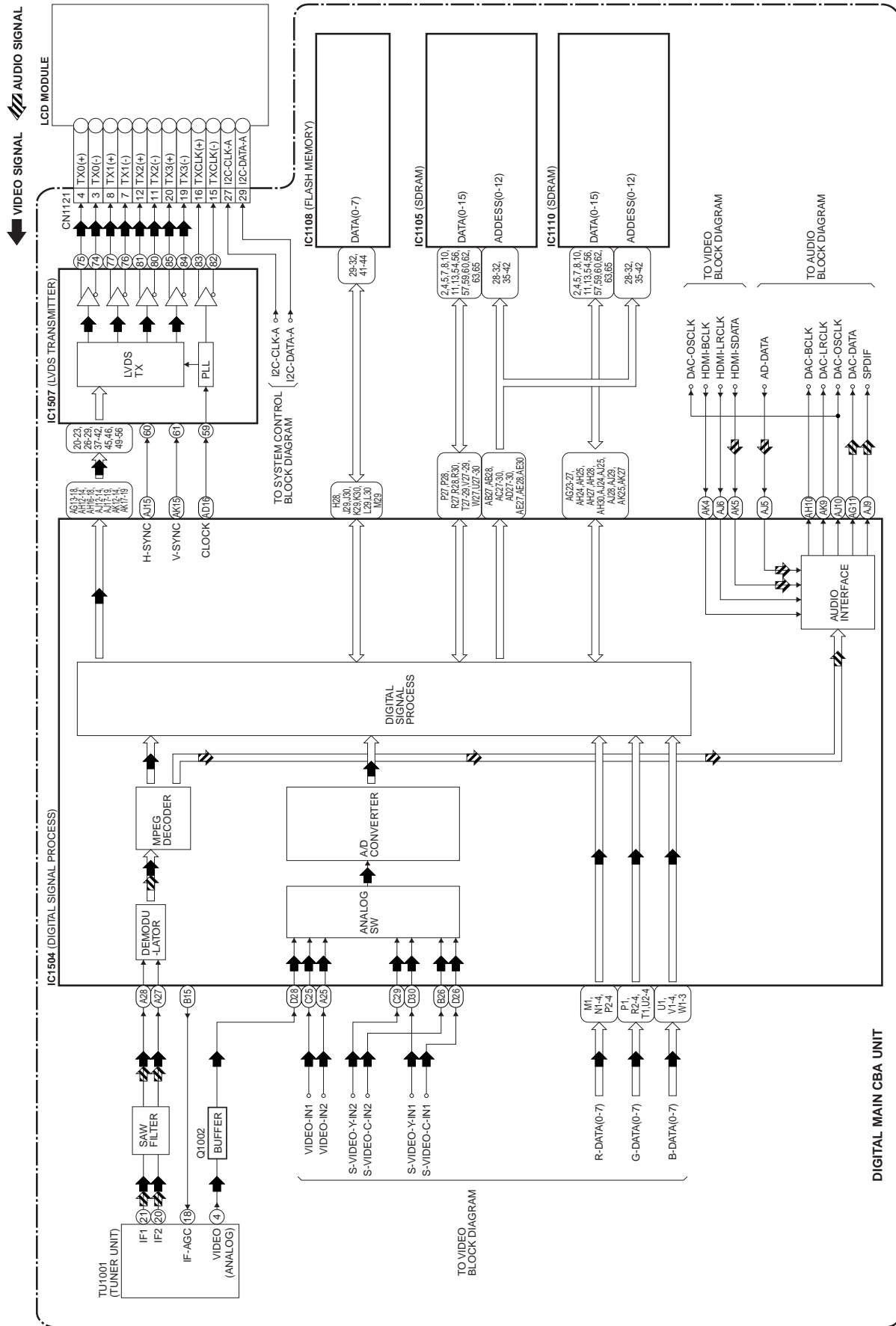
## System Control Block Diagram



# Video Input Block Diagram

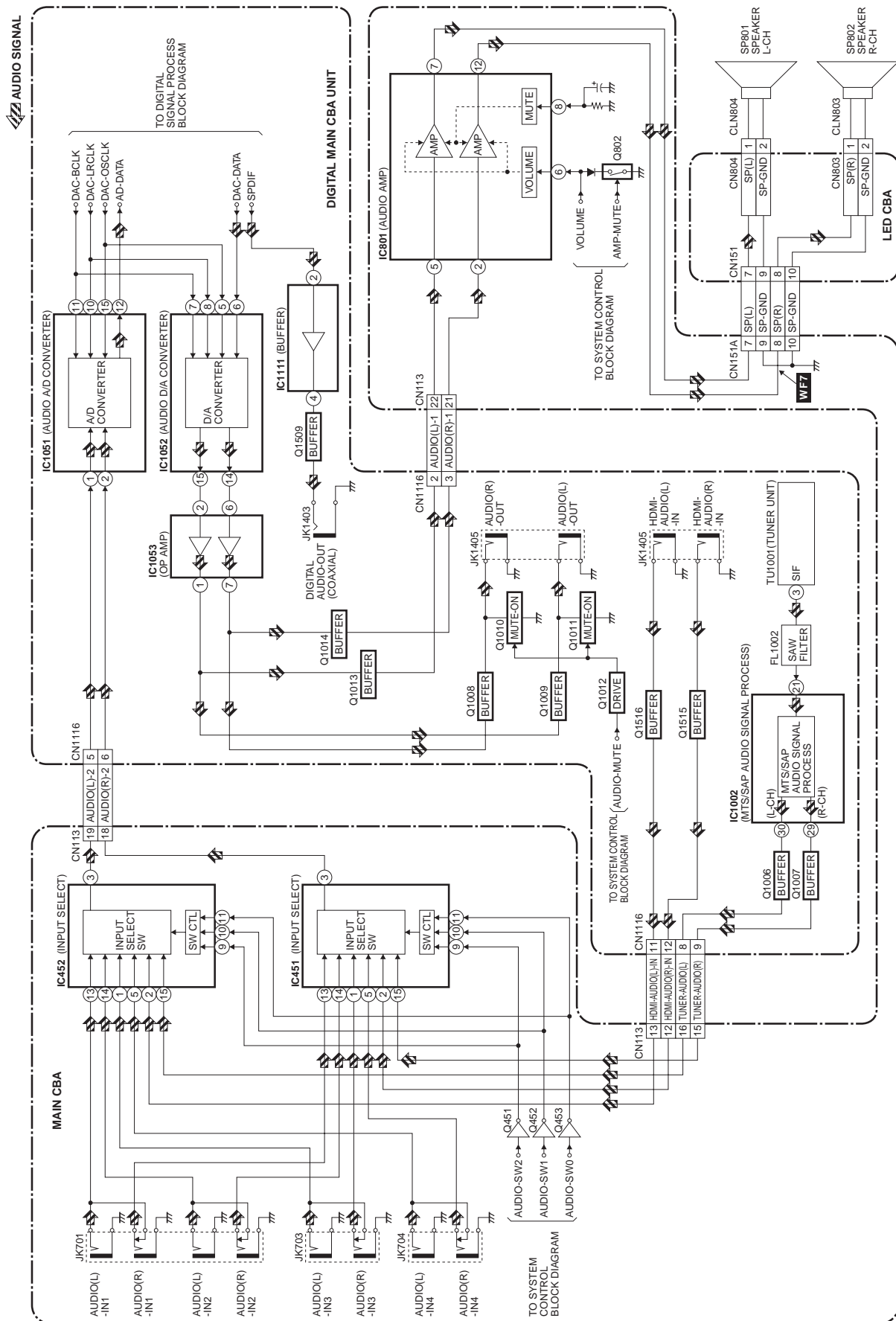


# Video Block Diagram

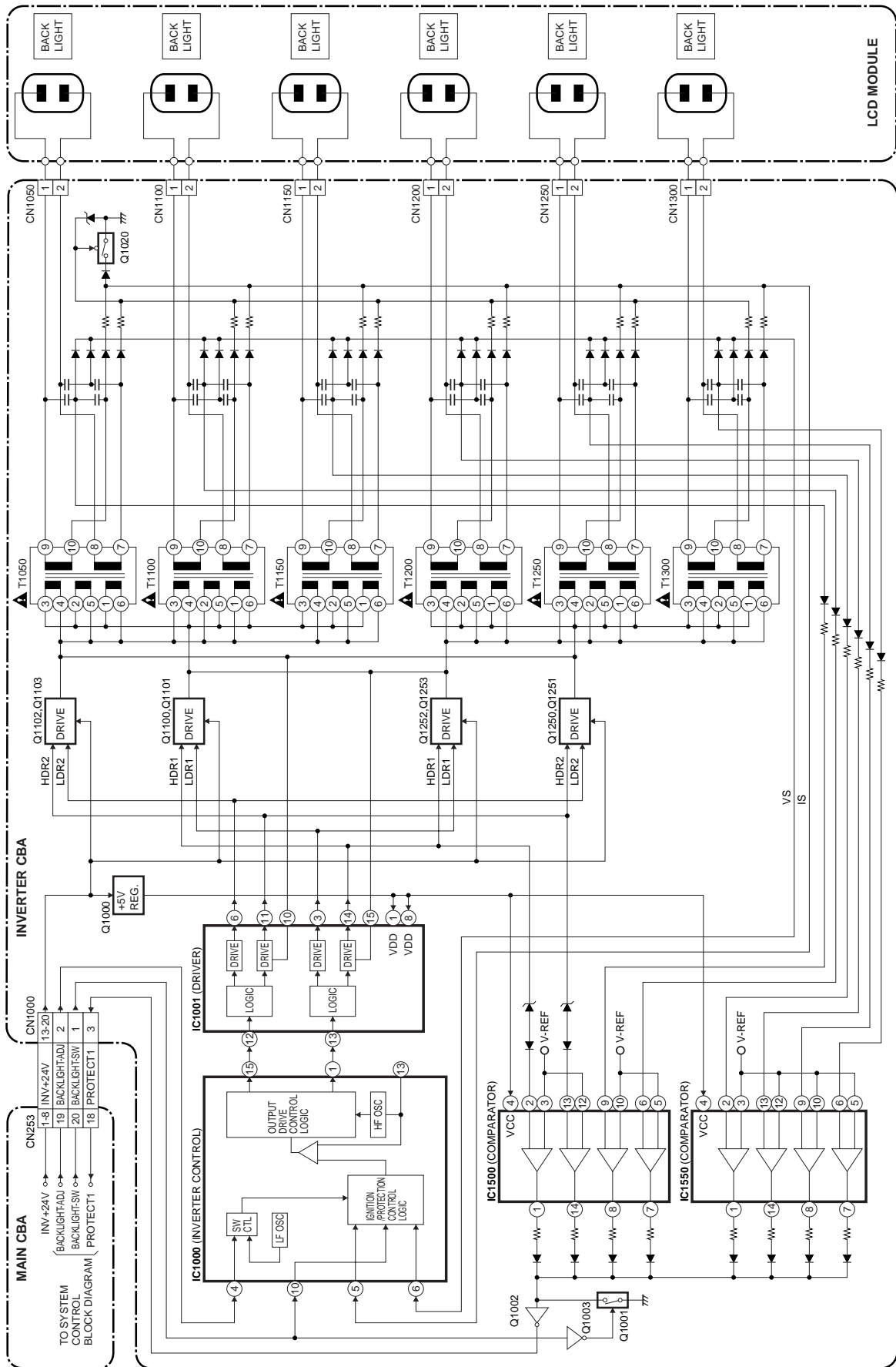




# Audio Block Diagram



# Inverter Block Diagram

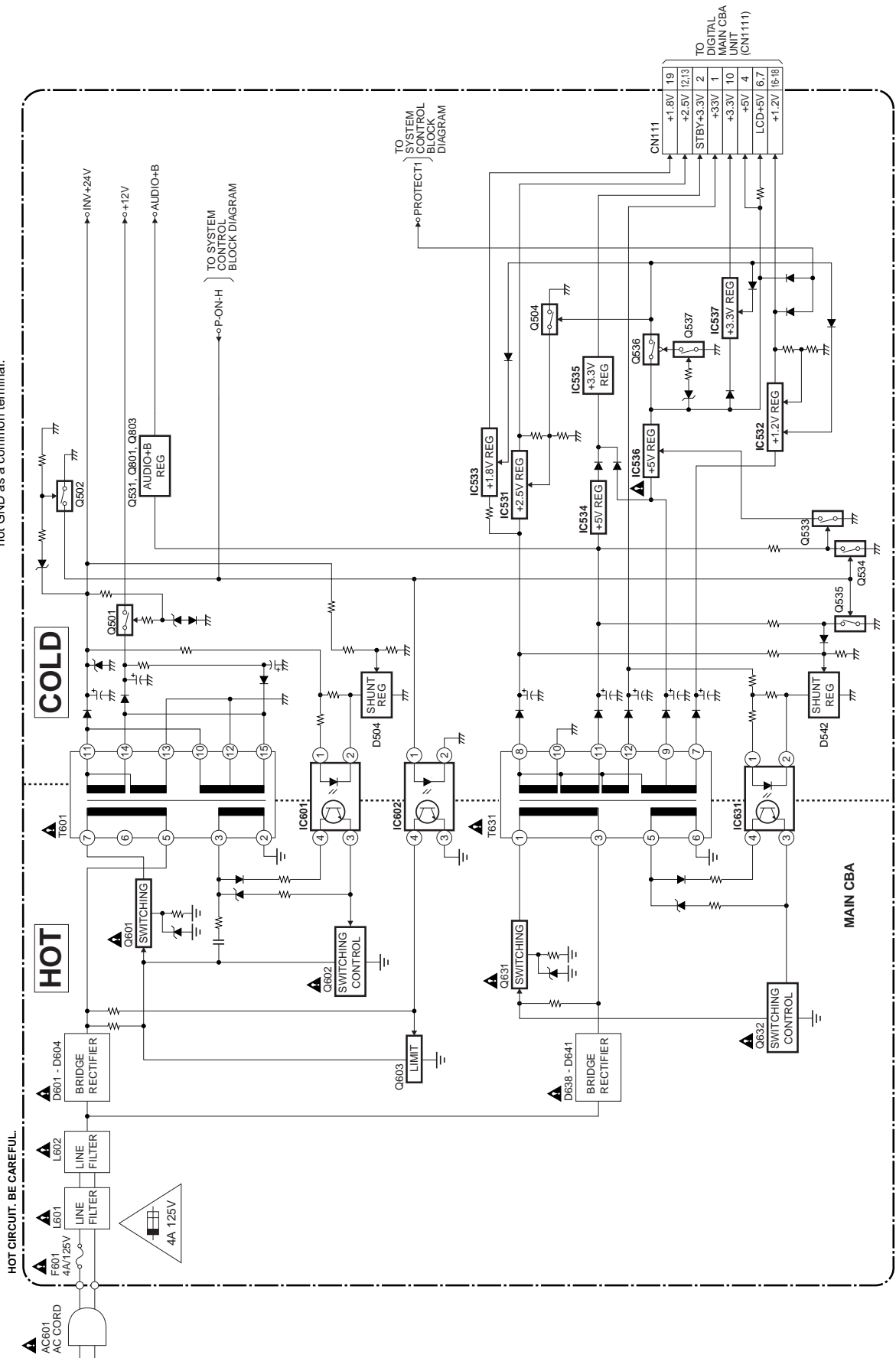


# Power Supply Block Diagram

**CAUTION ! :** For continued protection against risk of fire, replace only with same type 4 A, 125V fuse.  
**ATTENTION :** Utiliser un fusible de rechange de même type de 4A, 125V.

**NOTE:**  
 The voltage for parts in hot circuit is measured using hot GND as a common terminal.

**CAUTION !**  
 Fixed voltage (or Auto voltage selectable) power supply circuit is used in this unit. If Main Fuse (F601) is blown, check to see that all components in the power supply circuit are not defective before you connect the AC plug to the AC power supply. Otherwise it may cause some components in the power supply circuit to fail.



# SCHEMATIC DIAGRAMS / CBA'S AND TEST POINTS

## Standard Notes

Many electrical and mechanical parts in this chassis have special characteristics. These characteristics often pass unnoticed and the protection afforded by them cannot necessarily be obtained by using replacement components rated for higher voltage, wattage, etc. Replacement parts that have these special safety characteristics are identified in this manual and its supplements; electrical components having such features are identified by the mark “▲” in the schematic diagram and the parts list. Before replacing any of these components, read the parts list in this manual carefully. The use of substitute replacement parts that do not have the same safety characteristics as specified in the parts list may create shock, fire, or other hazards.

## Notes:

1. Do not use the part number shown on these drawings for ordering. The correct part number is shown in the parts list, and may be slightly different or amended since these drawings were prepared.
2. All resistance values are indicated in ohms ( $K = 10^3$ ,  $M = 10^6$ ).
3. Resistor wattages are 1/4W or 1/6W unless otherwise specified.
4. All capacitance values are indicated in  $\mu F$  ( $P = 10^{-6} \mu F$ ).
5. All voltages are DC voltages unless otherwise specified.

## Note of Capacitors:

ML --- Mylar Cap.    PP --- Metallized Film Cap.    SC --- Semiconductor Cap.    L --- Low Leakage type

## Temperature Characteristics of Capacitors are noted with the following:

B ---  $\pm 10\%$     CH ---  $0 \pm 60$  ppm/ $^{\circ}C$     CSL ---  $+350 \sim 1000$  ppm/ $^{\circ}C$

## Tolerance of Capacitors are noted with the following:

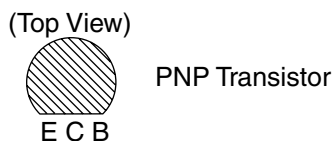
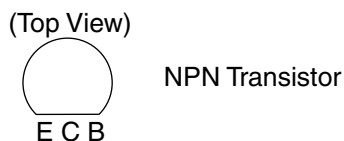
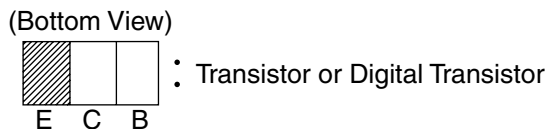
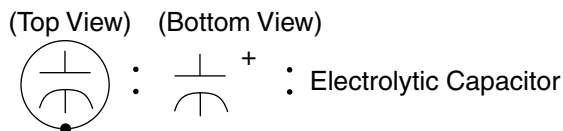
Z ---  $+80 \sim 20\%$

## Note of Resistors:

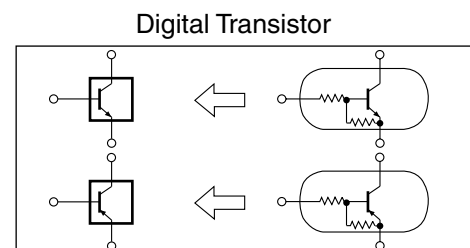
CEM --- Cement Res.    MTL --- Metal Res.    F --- Fuse Res.

## Capacitors and transistors are represented by the following symbols.

### CBA Symbols



### Schematic Diagram Symbols



## LIST OF CAUTION, NOTES, AND SYMBOLS USED IN THE SCHEMATIC DIAGRAMS ON THE FOLLOWING PAGES:

### 1. CAUTION:

**CAUTION:** FOR CONTINUED PROTECTION AGAINST RISK OF FIRE, REPLACE ONLY WITH SAME TYPE\_A,\_V FUSE.

**ATTENTION:** UTILISER UN FUSIBLE DE RECHANGE DE MÊME TYPE DE\_A,\_V.

### 2. CAUTION:

Fixed Voltage (or Auto voltage selectable) power supply circuit is used in this unit.

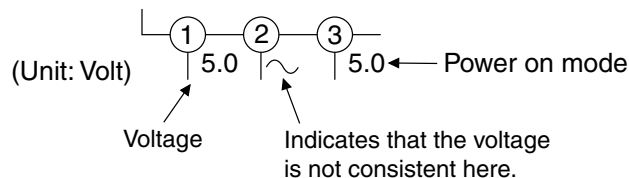
If Main Fuse (F601) is blown, first check to see that all components in the power supply circuit are not defective before you connect the AC plug to the AC power supply. Otherwise it may cause some components in the power supply circuit to fail.

### 3. Note:

- Do not use the part number shown on the drawings for ordering. The correct part number is shown in the parts list, and may be slightly different or amended since the drawings were prepared.
- To maintain original function and reliability of repaired units, use only original replacement parts which are listed with their part numbers in the parts list section of the service manual.

### 4. Voltage indications on the schematics are as shown below:

Plug the TV power cord into a standard AC outlet.:

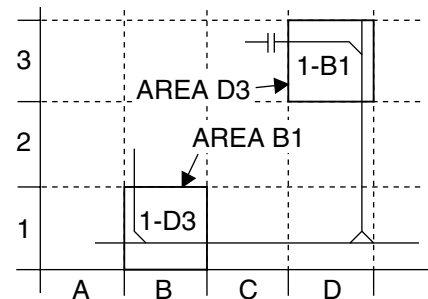


### 5. How to read converged lines

1-D3  
 ↑ Distinction Area  
 ↑ Line Number  
 (1 to 3 digits)

Examples:

- "1-D3" means that line number "1" goes to the line number "1" of the area "D3".
- "1-B1" means that line number "1" goes to the line number "1" of the area "B1".



### 6. Test Point Information

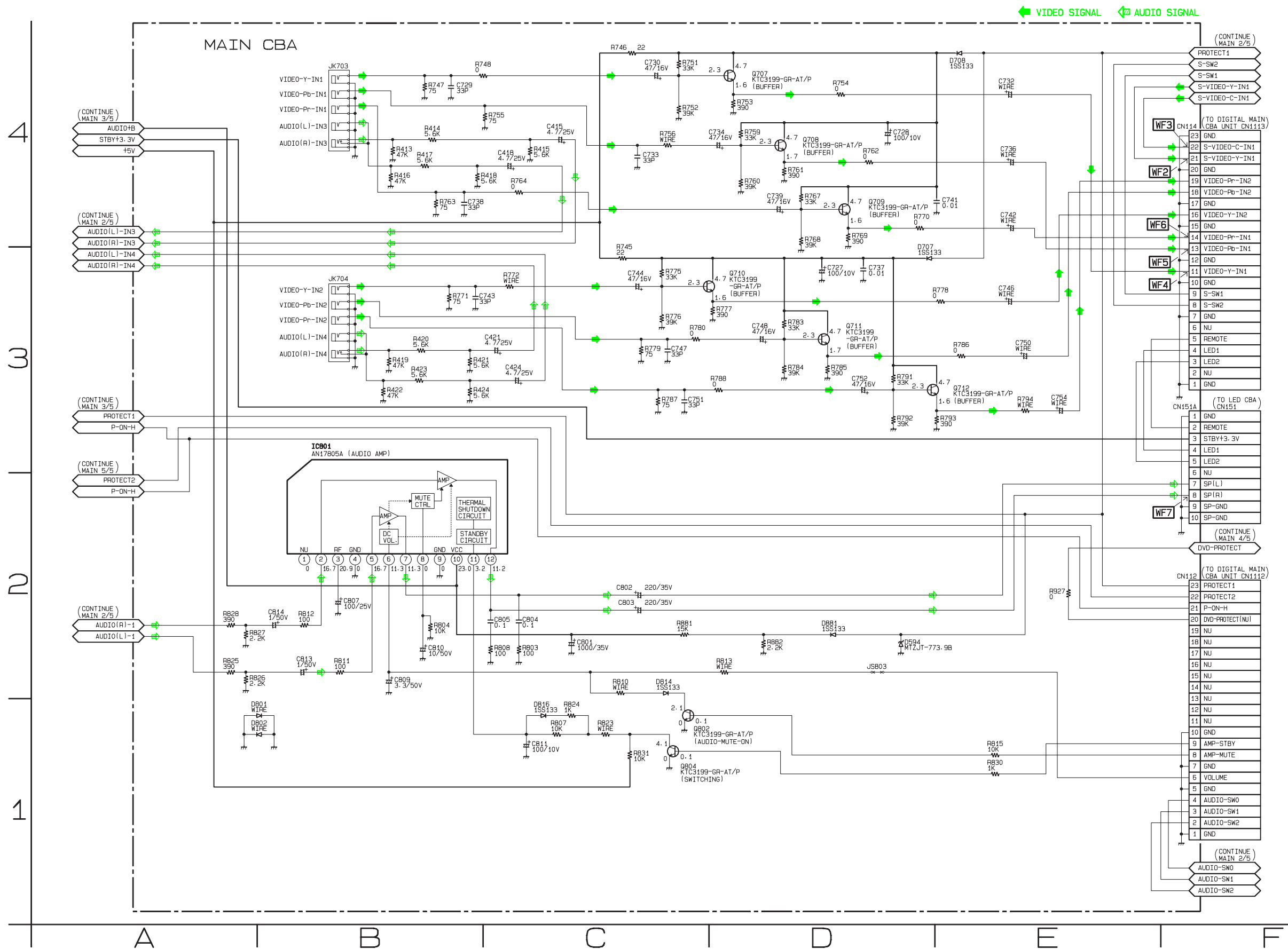
⊕ : Indicates a test point with a jumper wire across a hole in the PCB.

□→ : Used to indicate a test point with a component lead on foil side.

⊗ : Used to indicate a test point with no test pin.

● : Used to indicate a test point with a test pin.

# Main 1/5 Schematic Diagram



## VOLTAGE CHART

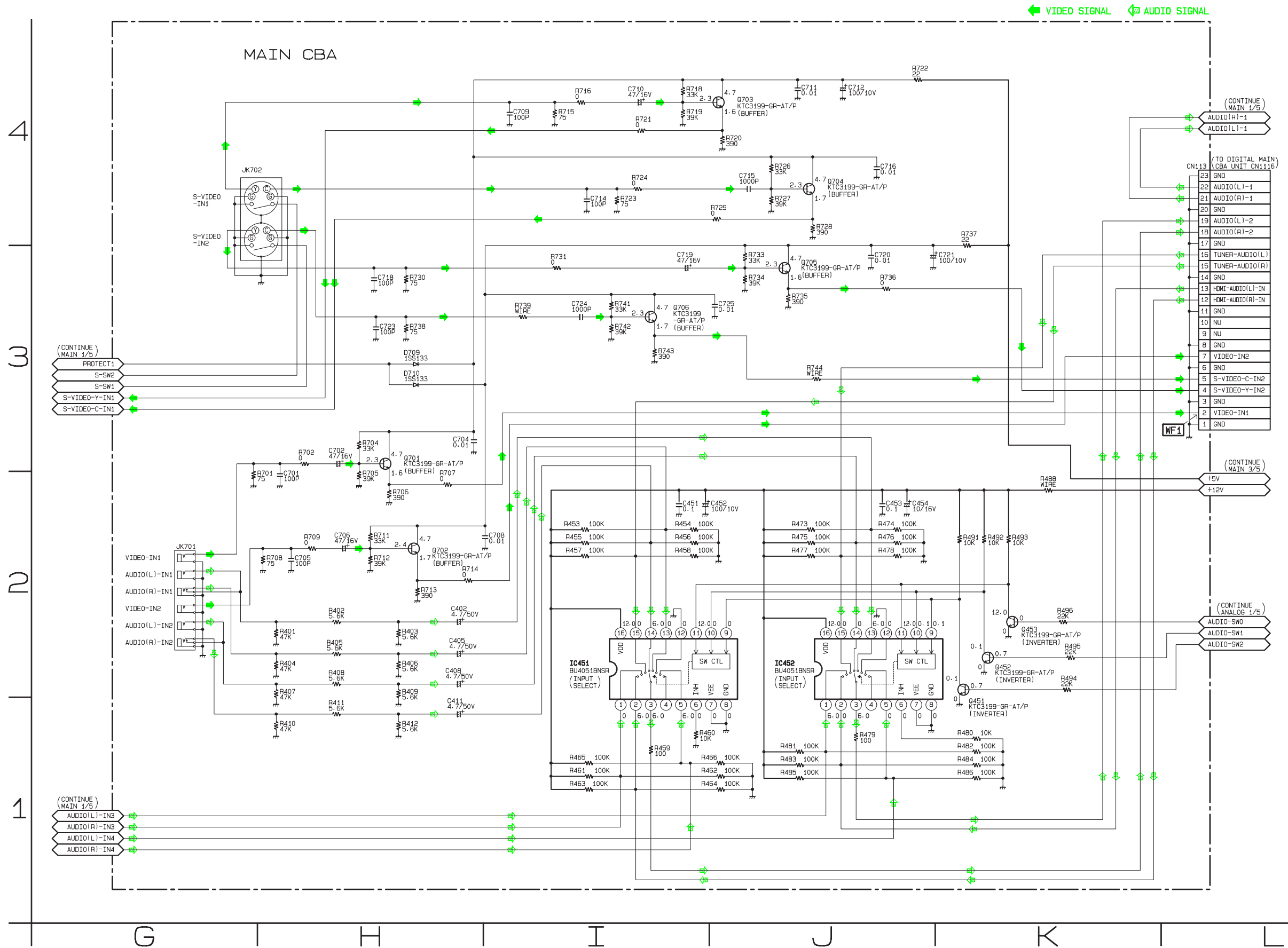
CN112

Pin No.	Voltage
1	0
2	3.3
3	3.3
4	0
5	0
6	1.1
7	0
8	0.1
9	0.1
10	0
11	0
12	0
13	0
14	0
15	0
16	0
17	0
18	0
19	0
20	3.4
21	3.2
22	1.1
23	2.3

CN114

Pin No.	Voltage
1	0
2	3.4
3	3.4
4	1.0
5	3.4
6	0
7	0
8	3.3
9	3.3
10	0
11	1.7
12	0
13	1.7
14	1.6
15	0
16	1.6
17	0
18	1.7
19	1.6
20	0
21	1.6
22	1.7
23	0

# Main 2/5 Schematic Diagram

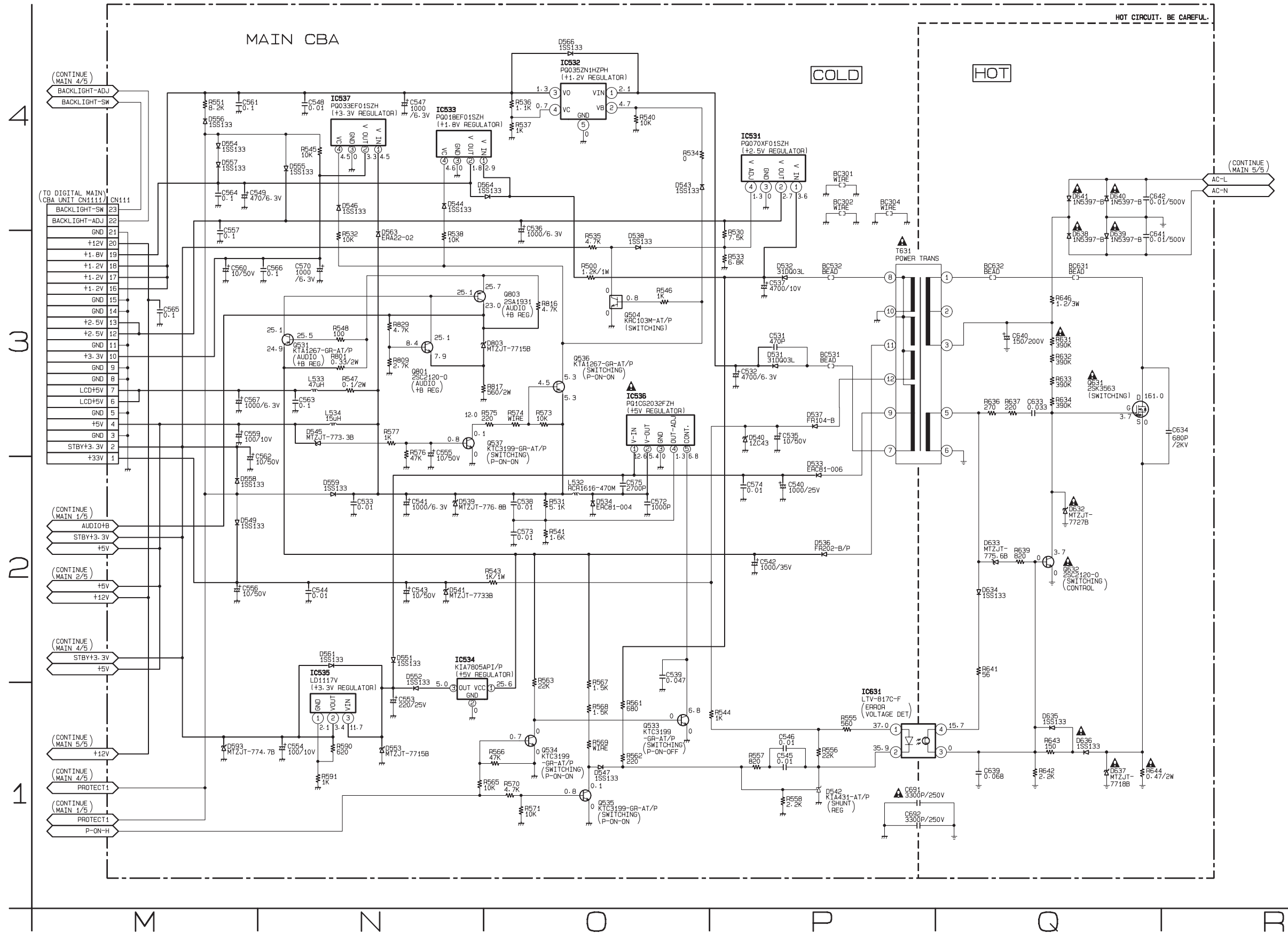


## VOLTAGE CHART

CN113  
(TO DIGITAL MAIN CBA UNIT CN1116)

Pin No.	Voltage
23	GND
22	AUDIO(L)-1
21	AUDIO(R)-1
20	GND
19	AUDIO(L)-2
18	AUDIO(R)-2
17	GND
16	TUNER-AUDIO(L)
15	TUNER-AUDIO(R)
14	GND
13	HDMI-AUDIO(L)-IN
12	HDMI-AUDIO(R)-IN
11	GND
10	NU
9	NU
8	GND
7	VIDEO-IN2
6	GND
5	S-VIDEO-C-IN2
4	S-VIDEO-Y-IN2
3	GND
2	VIDEO-IN1
1	GND
	(CONTINUE MAIN 3/5)
	+5V
	+12V
	(CONTINUE ANALOG 1/5)
	AUDIO-SW0
	AUDIO-SW1
	AUDIO-SW2

# Main 3/5 Schematic Diagram



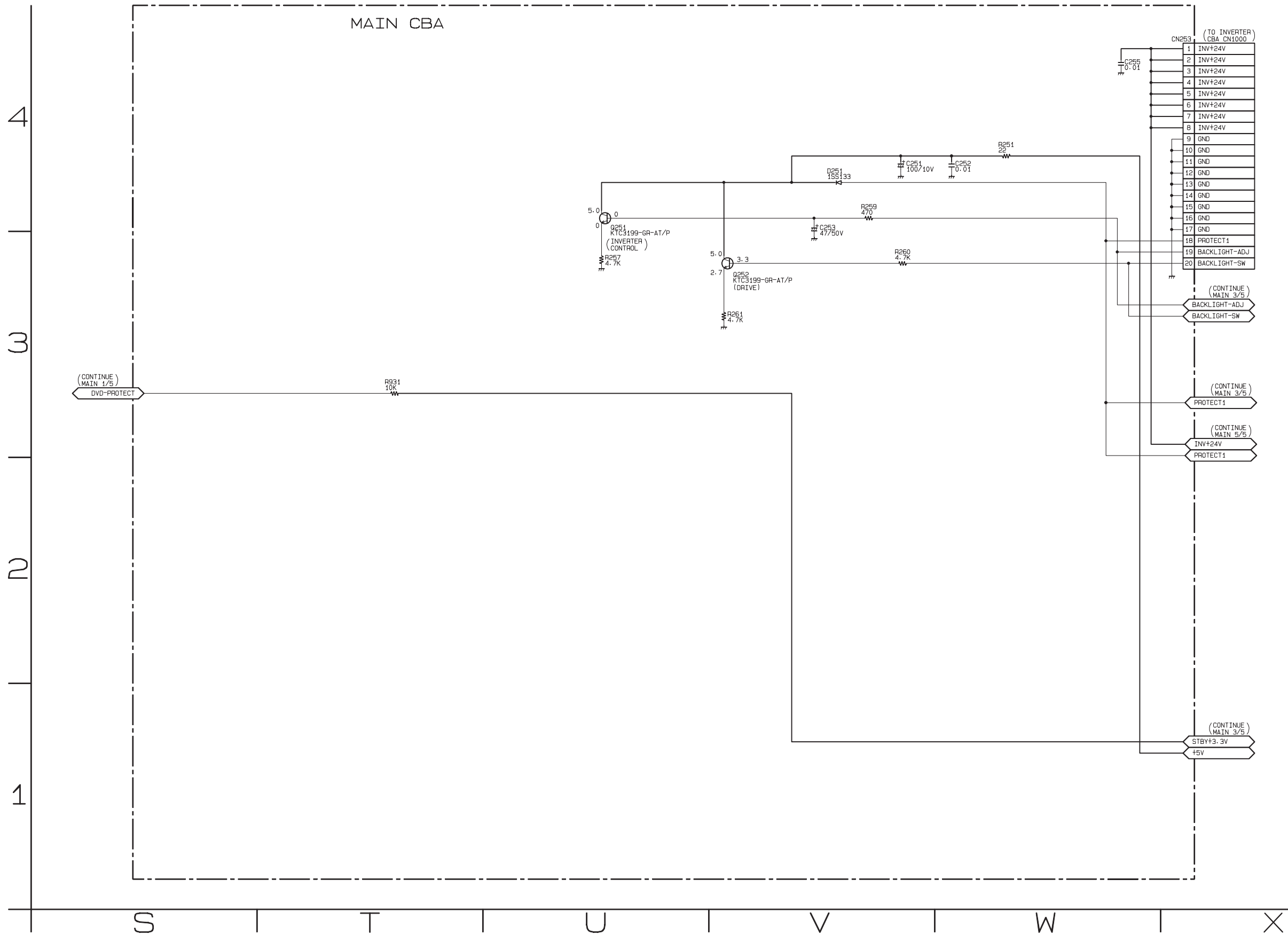
## VOLTAGE CHART

CN111

Pin No.	Voltage
1	32.7
2	3.4
3	0
4	5.0
5	0
6	5.0
7	5.0
8	0
9	0
10	3.3
11	0
12	2.7
13	2.7
14	0
15	0
16	1.3
17	1.3
18	1.3
19	1.8
20	12
21	0
22	0
23	3.3



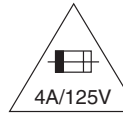
# Main 4/5 Schematic Diagram



# Main 5/5 Schematic Diagram

## CAUTION !

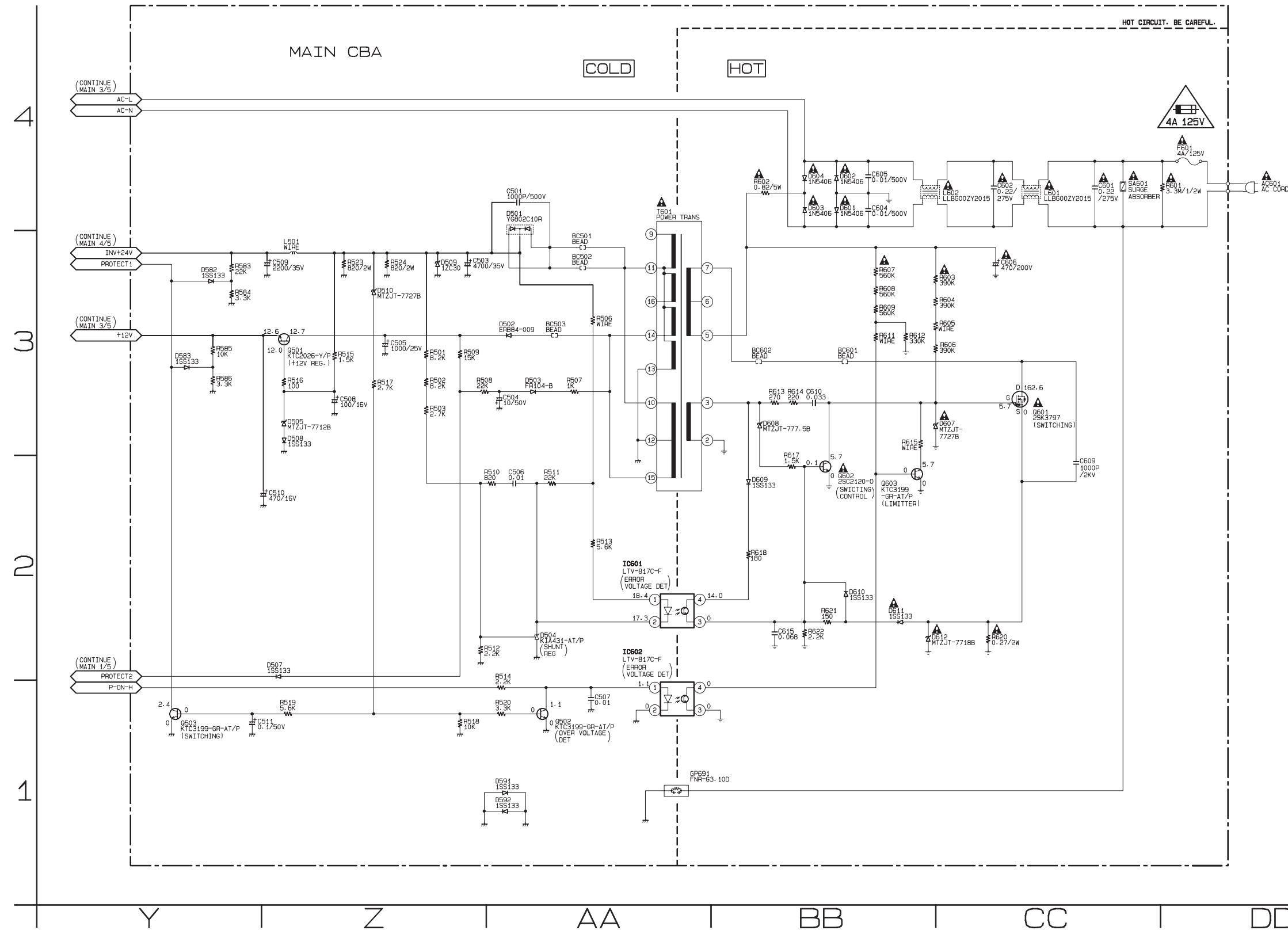
Fixed voltage (or Auto voltage selectable) power supply circuit is used in this unit.  
 If Main Fuse (F601) is blown, check to see that all components in the power supply circuit are not defective before you connect the AC plug to the AC power supply.  
 Otherwise it may cause some components in the power supply circuit to fail.



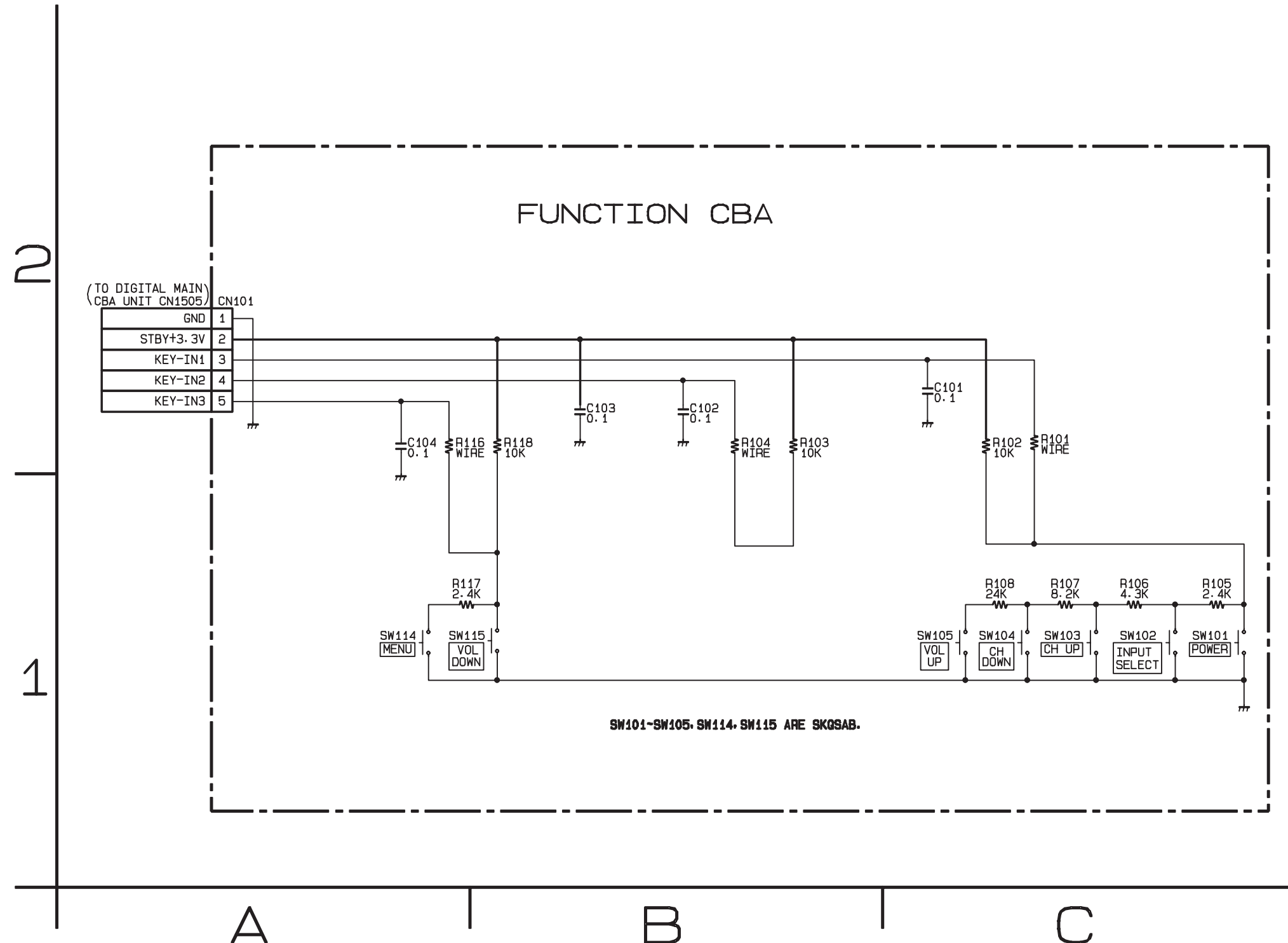
**CAUTION ! :** For continued protection against risk of fire,  
 replace only with same type 4 A, 125V fuse.  
**ATTENTION :** Utiliser un fusible de rechange de même type de 4A, 125V.

## NOTE:

The voltage for parts in hot circuit is measured using hot GND as a common terminal.



# Function Schematic Diagram

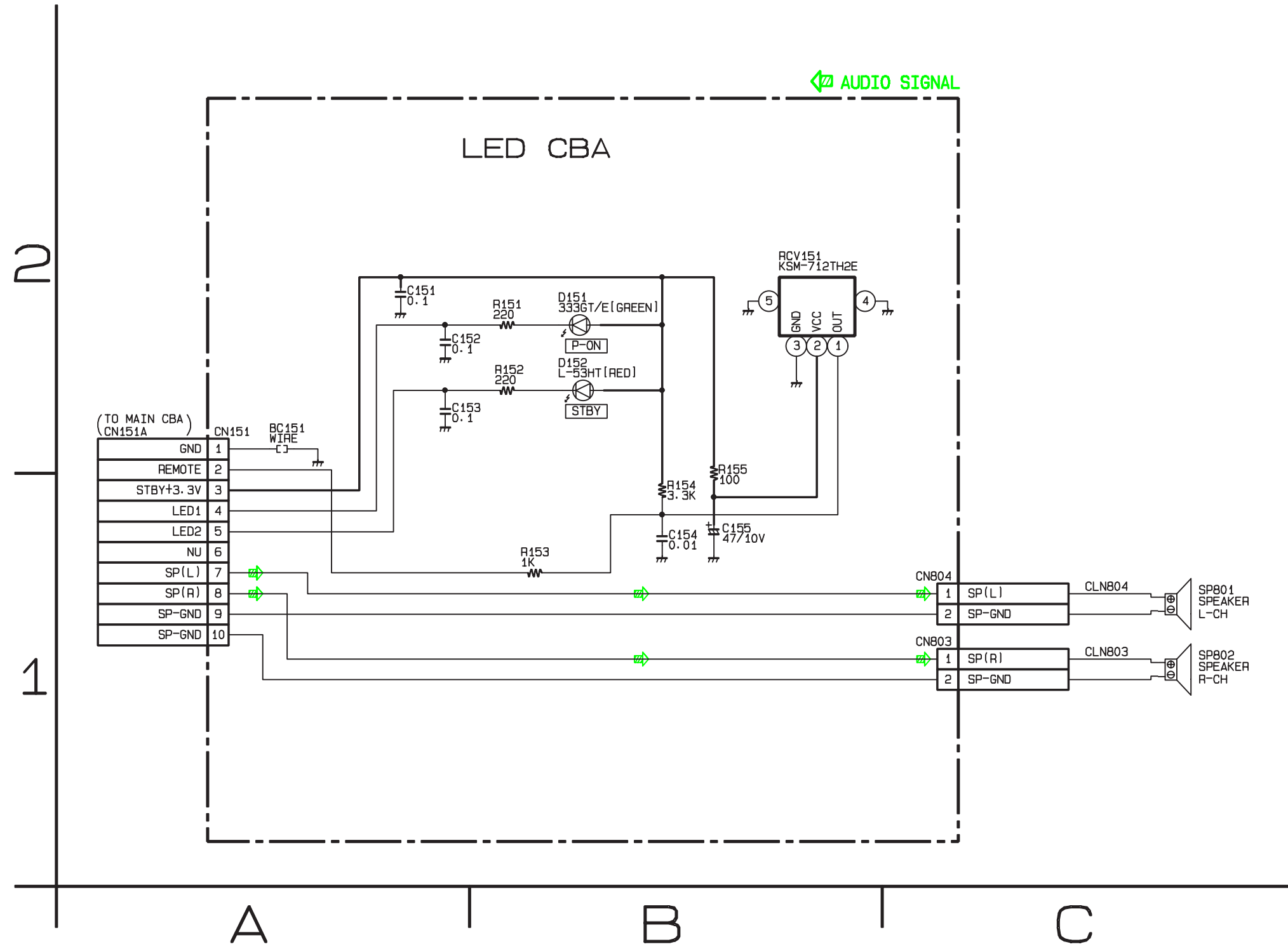


## VOLTAGE CHART

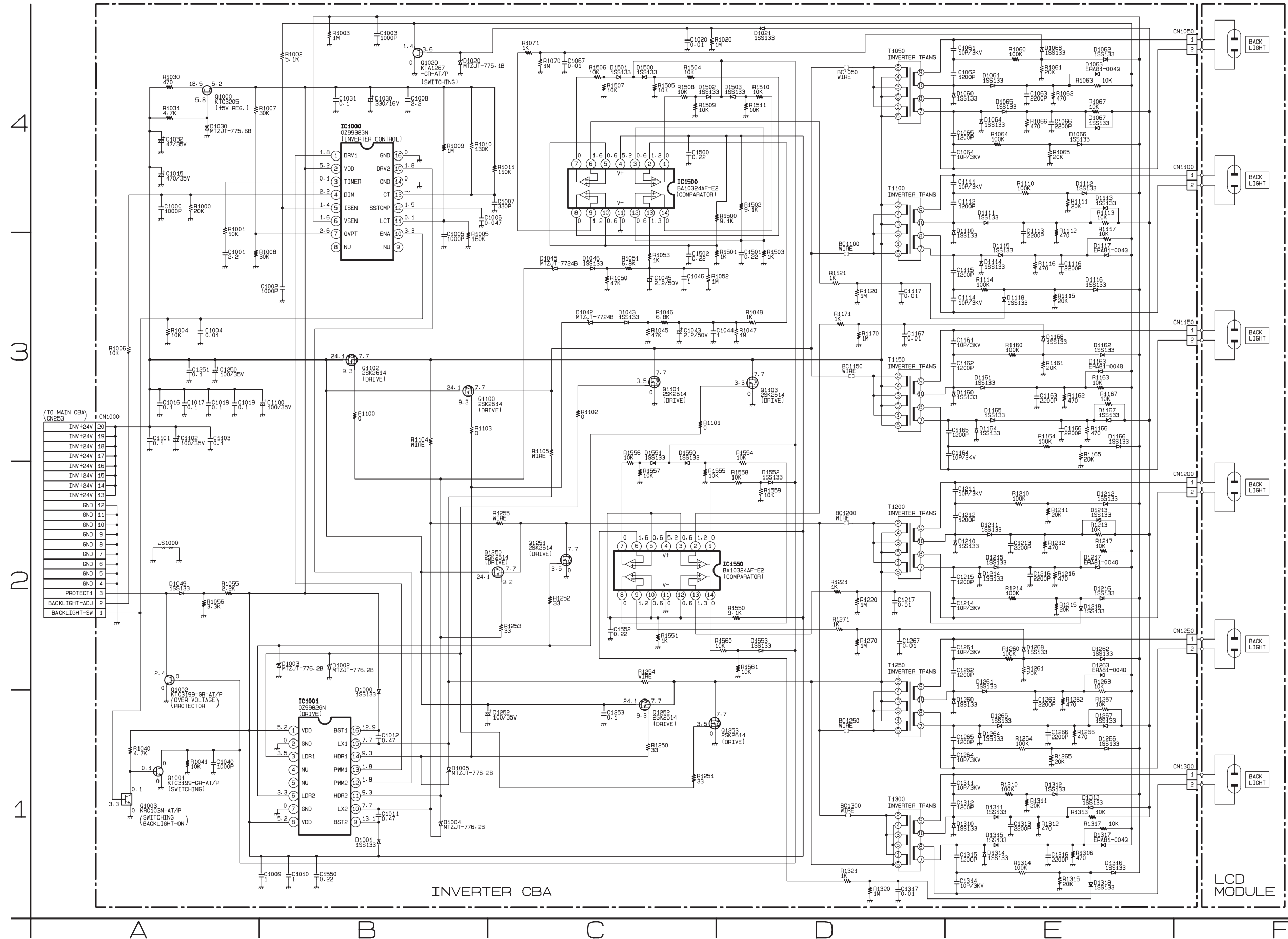
CN101

Pin No.	Voltage
1	0
2	3.4
3	3.4
4	3.4
5	3.4

# LED Schematic Diagram

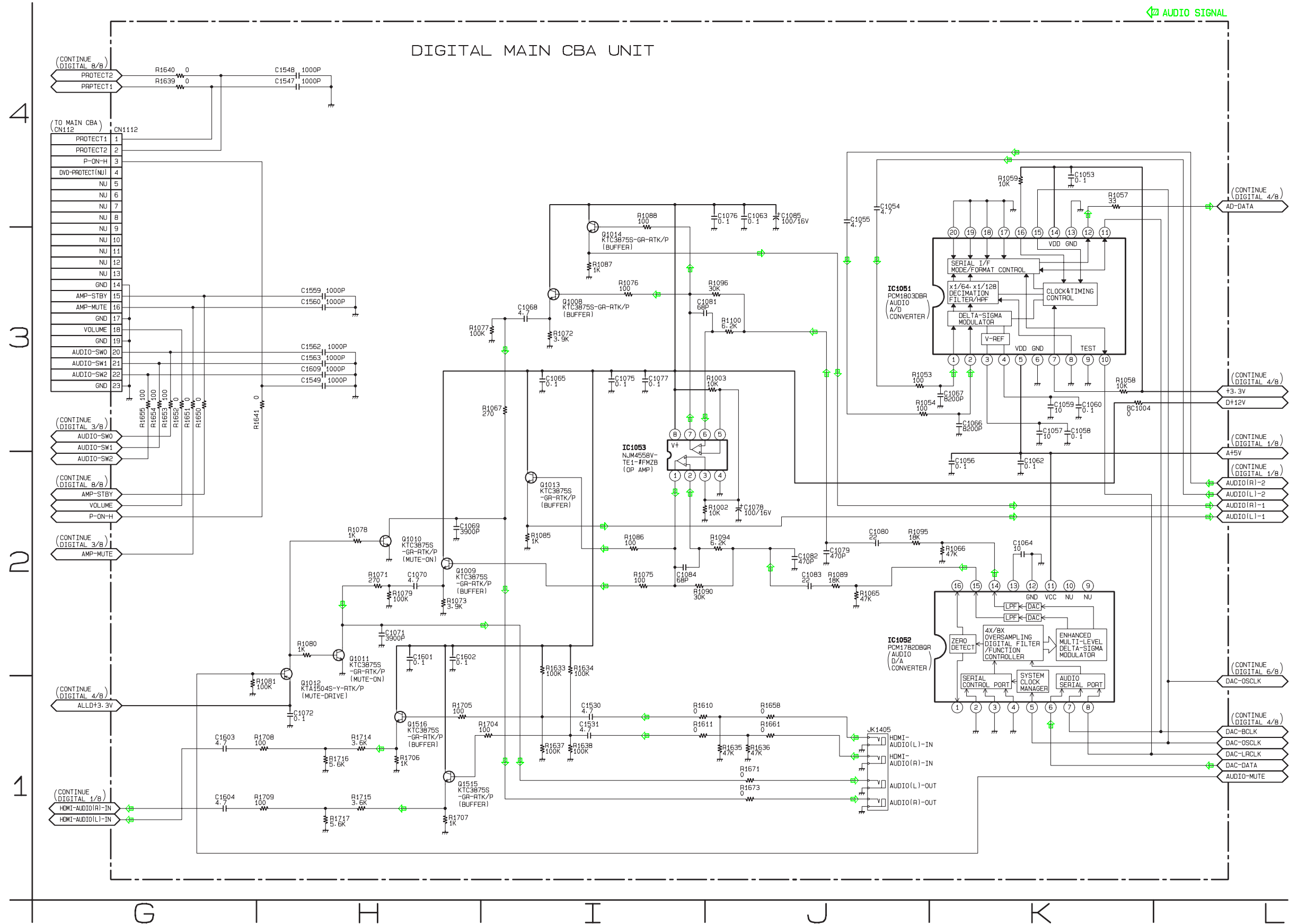


# Inverter Schematic Diagram





Digital Main 2/8 Schematic Diagram

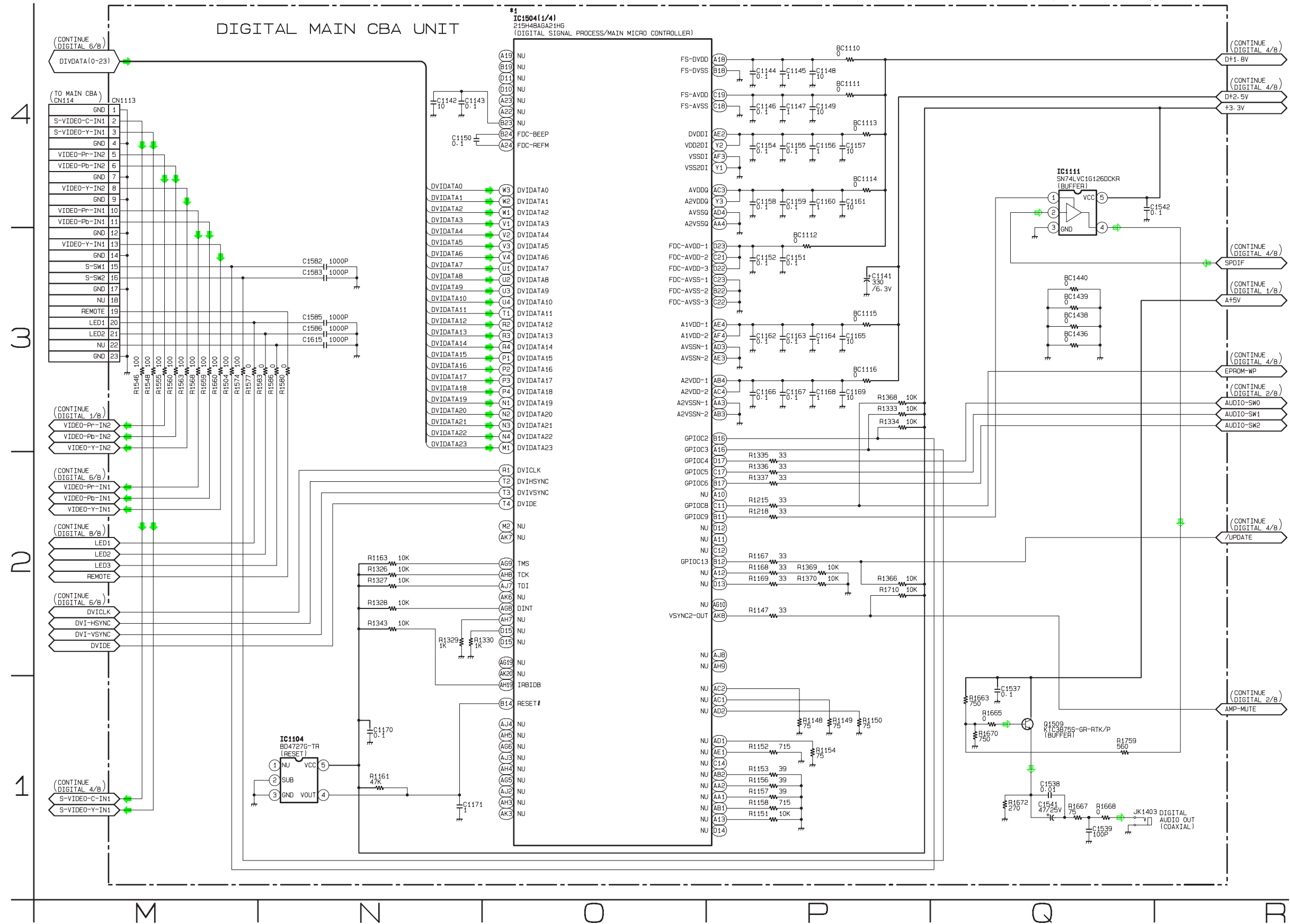


# Digital Main 3/8 Schematic Diagram

**\*1 NOTE:**

1. The order of pins shown in this diagram is different from that of actual IC1504.
2. IC1504 is divided into four and shown as IC1504 (1/4) ~ IC1504 (4/4) in this Digital Main Schematic Diagram Section.

← VIDEO SIGNAL   ← AUDIO SIGNAL

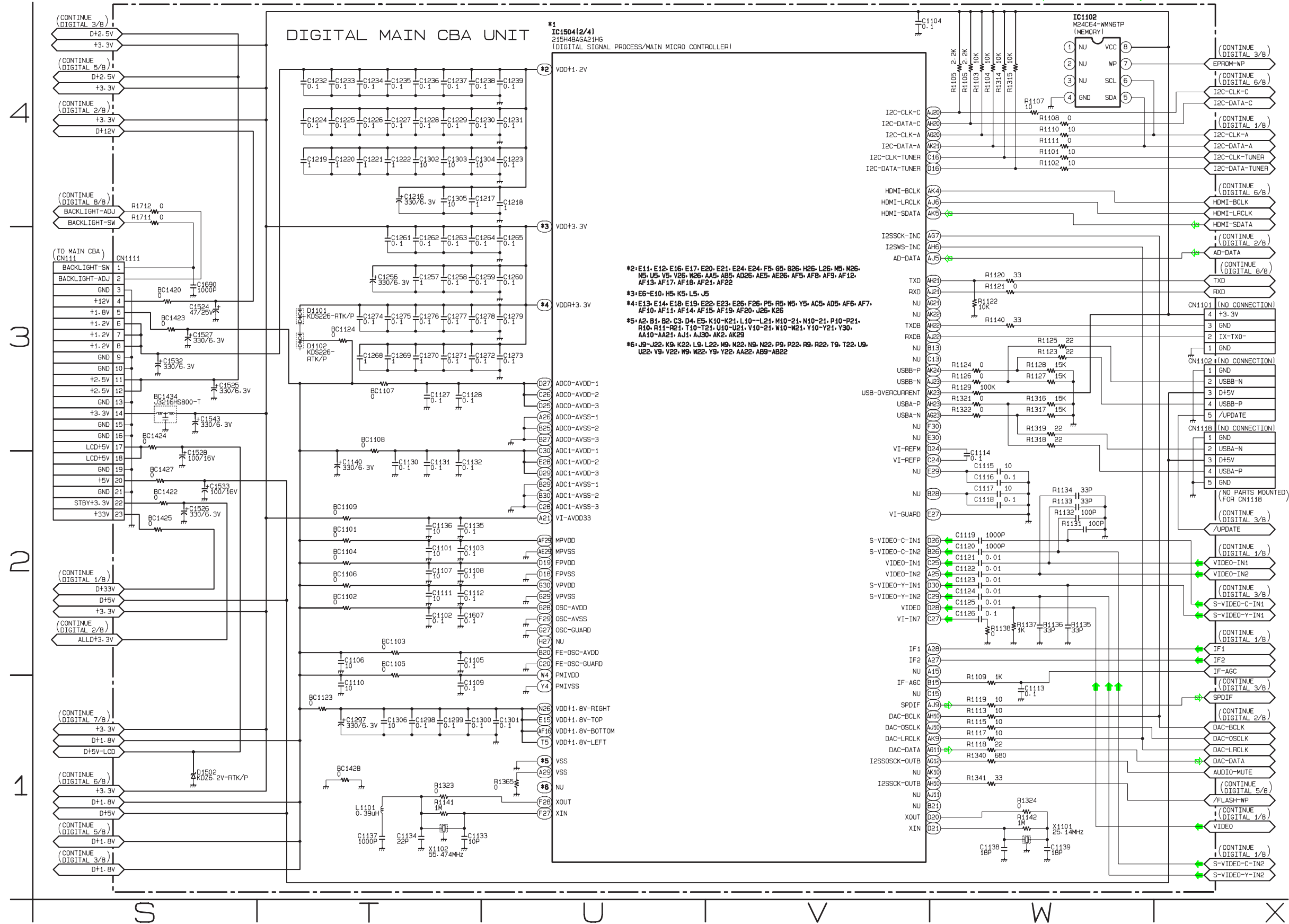




# Digital Main 4/8 Schematic Diagram

**\*1 NOTE:**

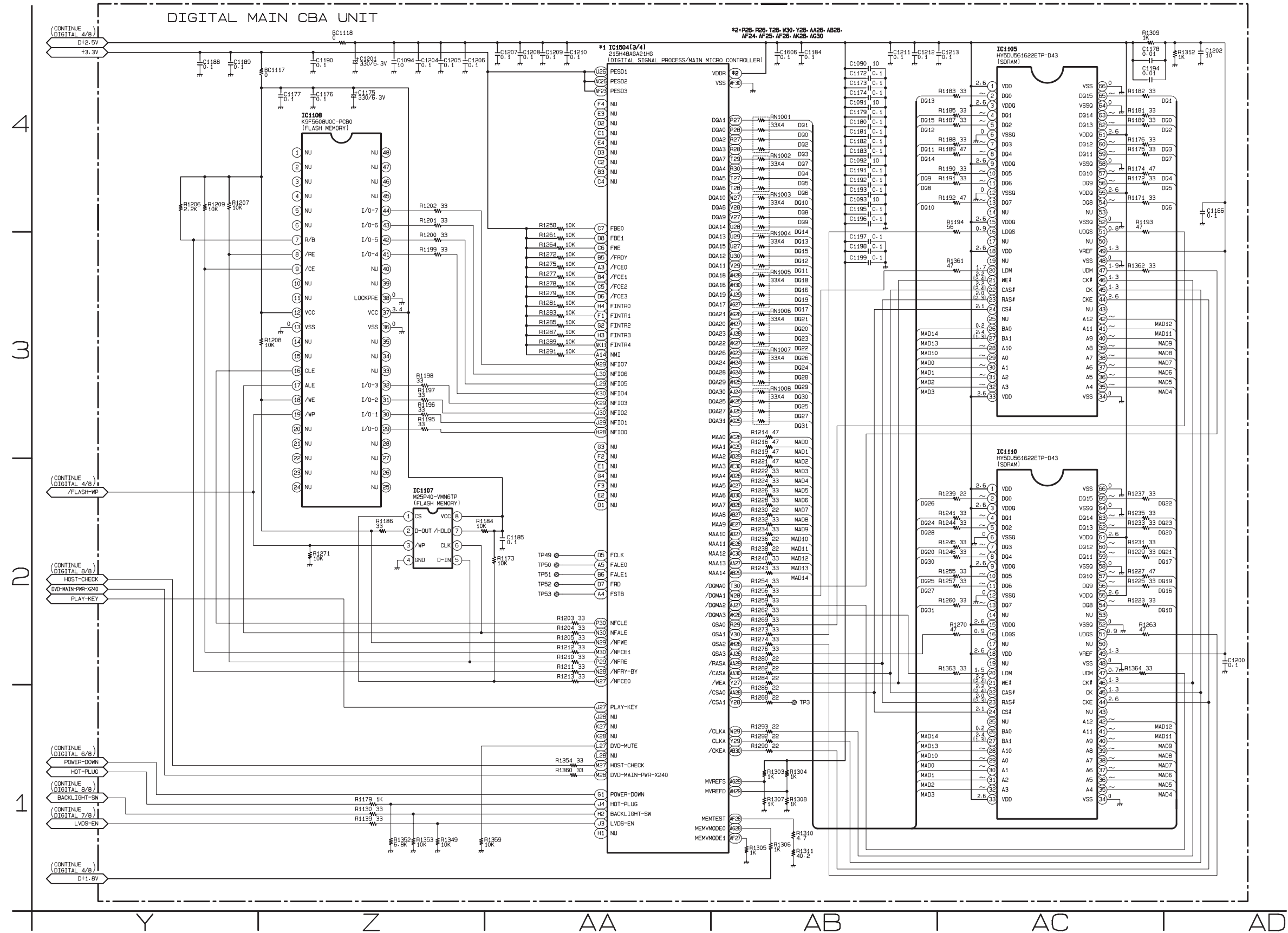
1. The order of pins shown in this diagram is different from that of actual IC1504.
2. IC1504 is divided into four and shown as IC1504 (1/4) ~ IC1504 (4/4) in this Digital Main Schematic Diagram Section.



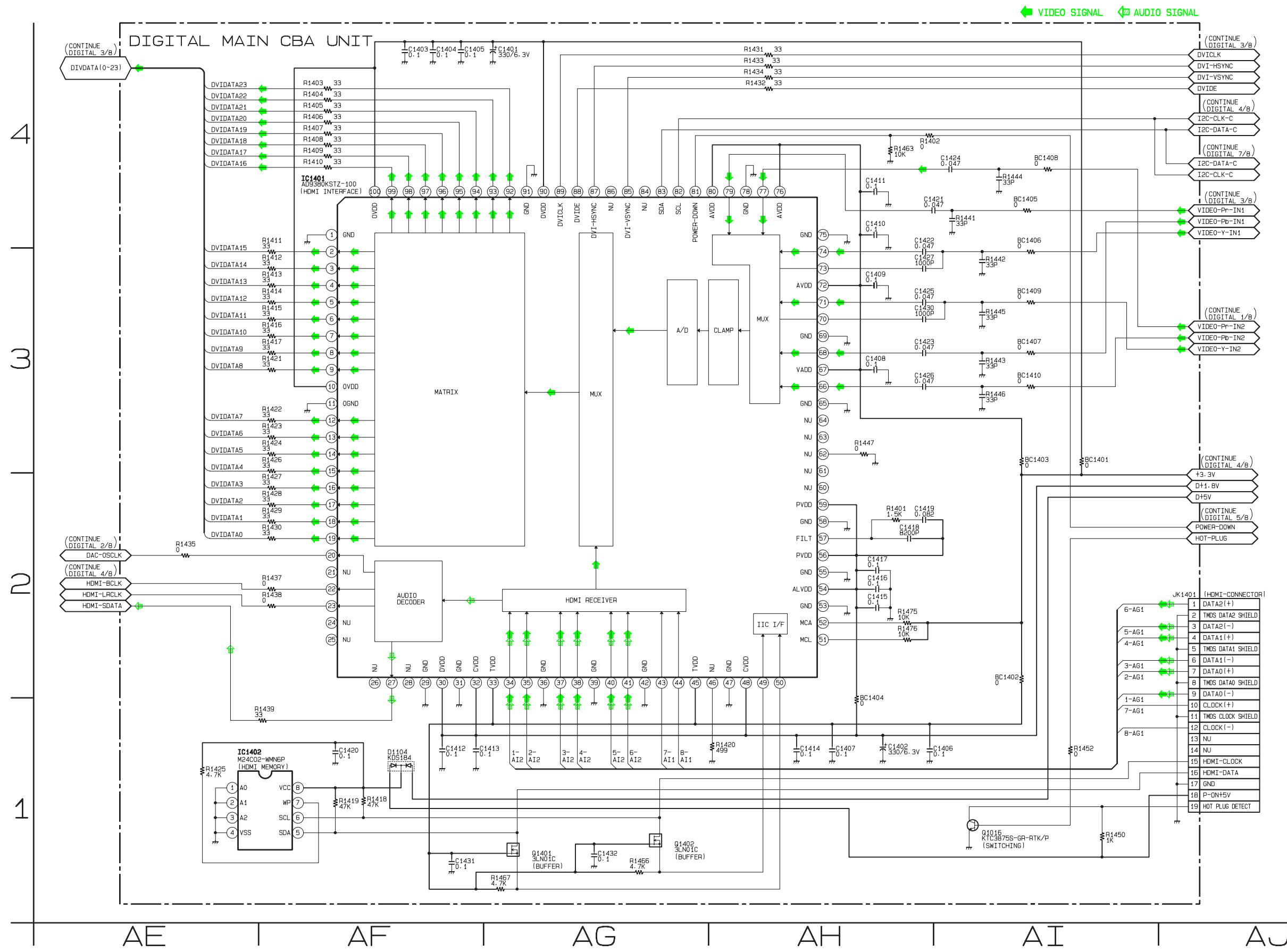
# Digital Main 5/8 Schematic Diagram

**\*1 NOTE:**

1. The order of pins shown in this diagram is different from that of actual IC1504.
2. IC1504 is divided into four and shown as IC1504 (1/4) ~ IC1504 (4/4) in this Digital Main Schematic Diagram Section.



# Digital Main 6/8 Schematic Diagram

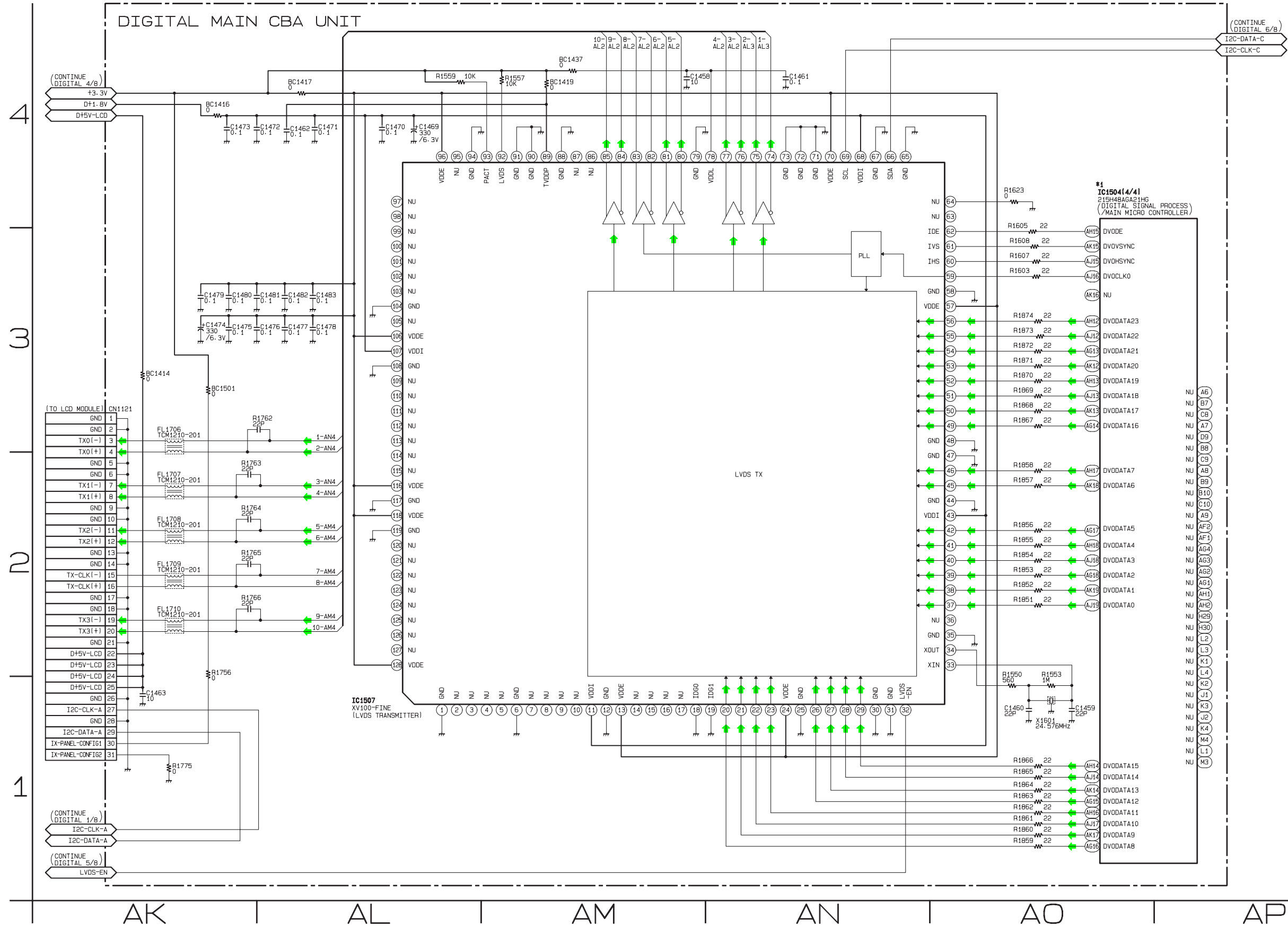


# Digital Main 7/8 Schematic Diagram

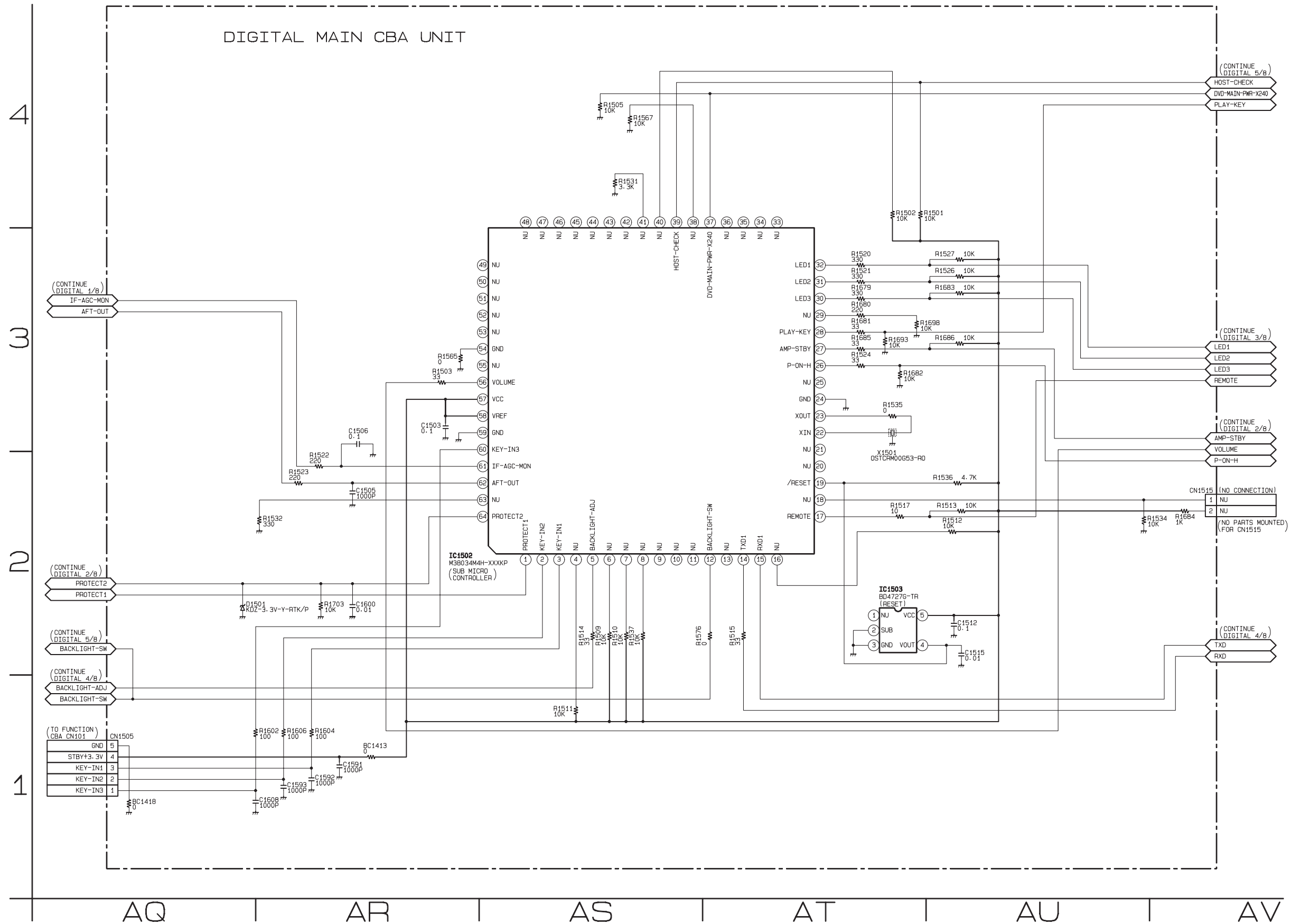
**\*1 NOTE:**

- The order of pins shown in this diagram is different from that of actual IC1504.
- IC1504 is divided into four and shown as IC1504 (1/4) ~ IC1504 (4/4) in this Digital Main Schematic Diagram Section.

VIDEO SIGNAL



# Digital Main 8/8 Schematic Diagram

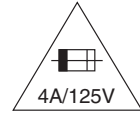




# Main CBA Top View

## CAUTION !

Fixed voltage (or Auto voltage selectable) power supply circuit is used in this unit.  
If Main Fuse (F601) is blown, check to see that all components in the power supply circuit are not defective before you connect the AC plug to the AC power supply.  
Otherwise it may cause some components in the power supply circuit to fail.

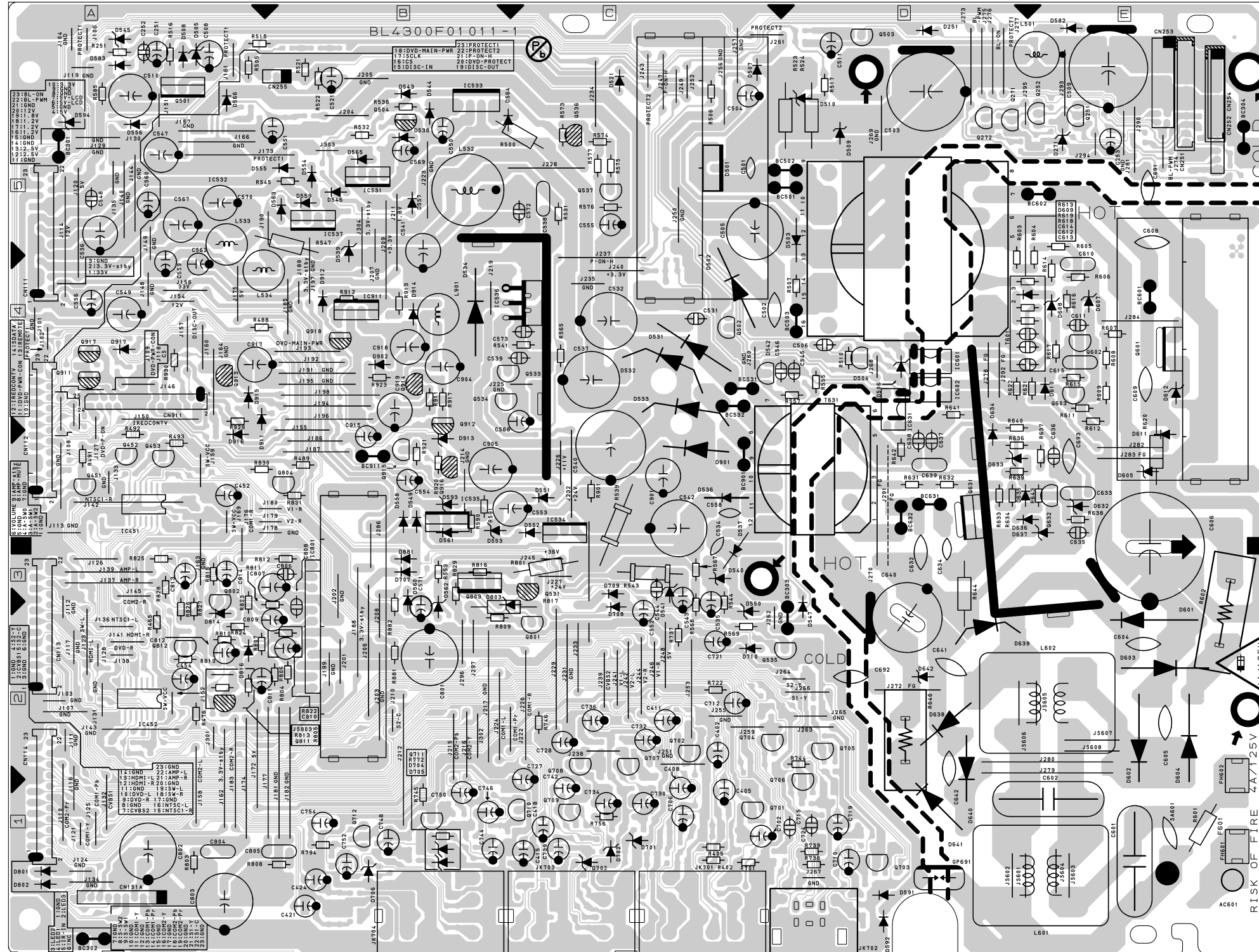


**CAUTION ! :** For continued protection against risk of fire, replace only with same type 4 A, 125V fuse.  
**ATTENTION :** Utiliser un fusible de rechange de même type de 4A, 125V.

## NOTE:

The voltage for parts in hot circuit is measured using hot GND as a common terminal.

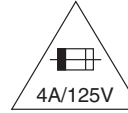
Because a hot chassis ground is present in the power supply circuit, an isolation transformer must be used.  
Also, in order to have the ability to increase the input slowly, when troubleshooting this type power supply circuit, a variable isolation transformer is required.



# Main CBA Bottom View

## CAUTION !

Fixed voltage (or Auto voltage selectable) power supply circuit is used in this unit.  
If Main Fuse (F601) is blown, check to see that all components in the power supply circuit are not defective before you connect the AC plug to the AC power supply.  
Otherwise it may cause some components in the power supply circuit to fail.



**CAUTION ! :** For continued protection against risk of fire, replace only with same type 4 A, 125V fuse.  
**ATTENTION :** Utiliser un fusible de rechange de même type de 4A, 125V.

## NOTE:

The voltage for parts in hot circuit is measured using hot GND as a common terminal.

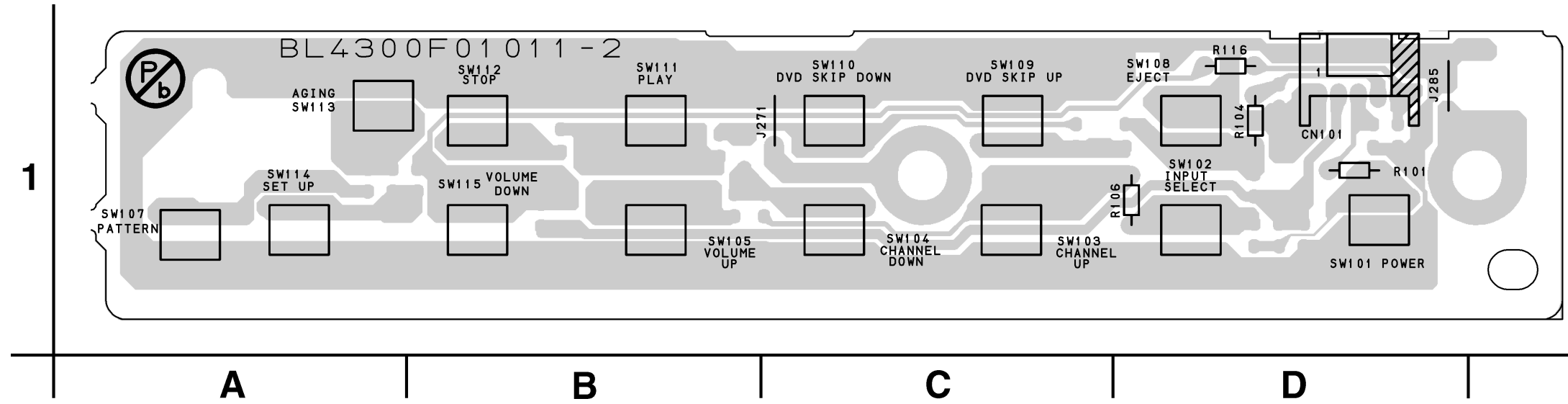
Because a hot chassis ground is present in the power supply circuit, an isolation transformer must be used. Also, in order to have the ability to increase the input slowly, when troubleshooting this type power supply circuit, a variable isolation transformer is required.



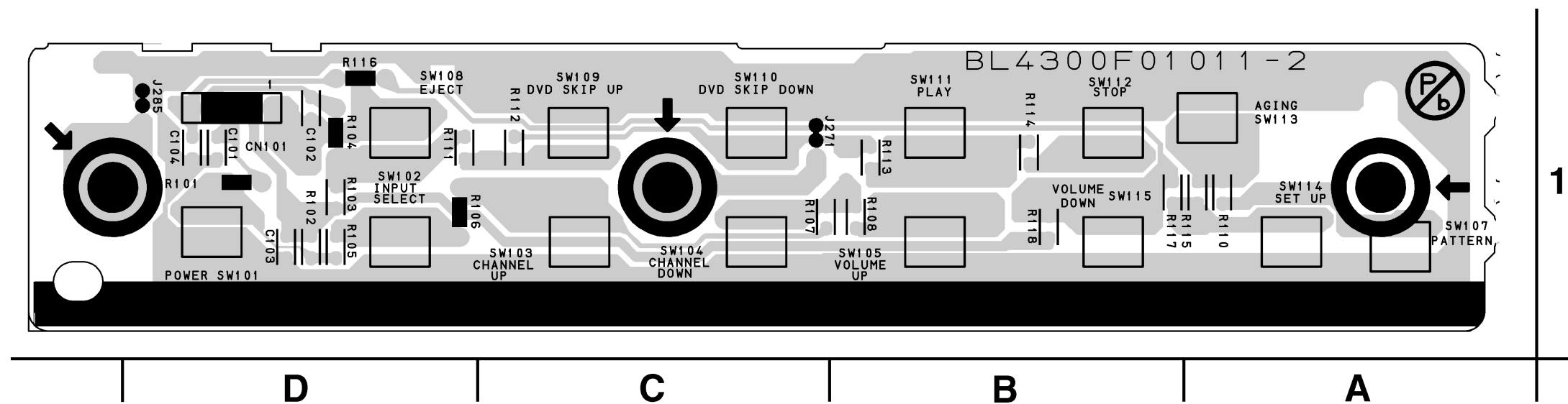
- WF1**  
PIN 2 OF  
CN113
- WF3**  
PIN 22 OF  
CN114
- WF2**  
PIN 21 OF  
CN114
- WF6**  
PIN 14 OF  
CN114
- WF5**  
PIN 13 OF  
CN114
- WF4**  
PIN 11 OF  
CN114
- WF7**  
PIN 8 OF  
CN151A

4A/125V  
RISK OF FIRE  
REPLACE FUSE AS MARKED.

### Function CBA Top View

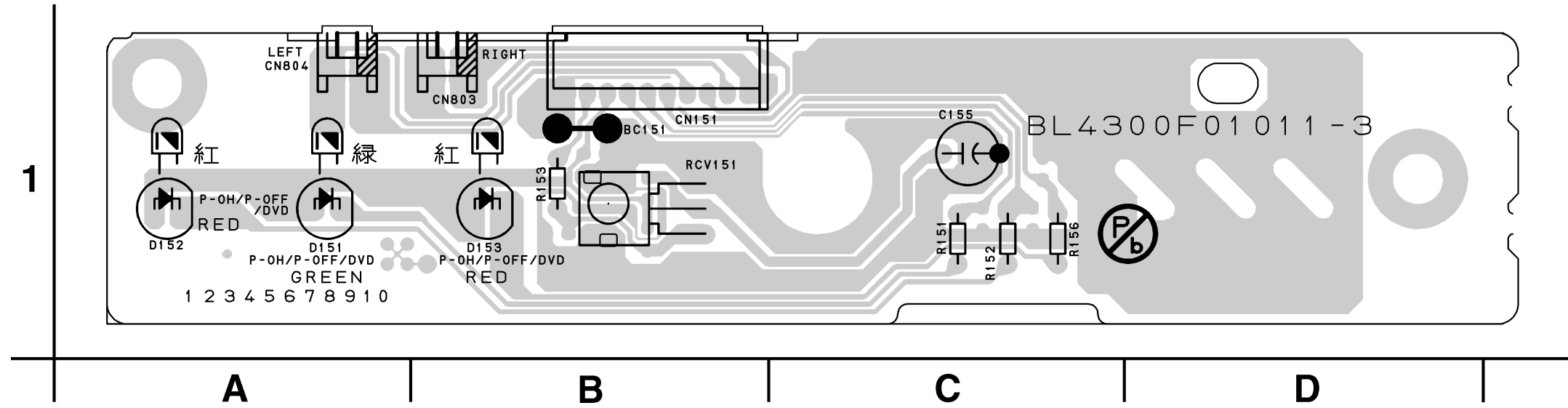


### Function CBA Bottom View

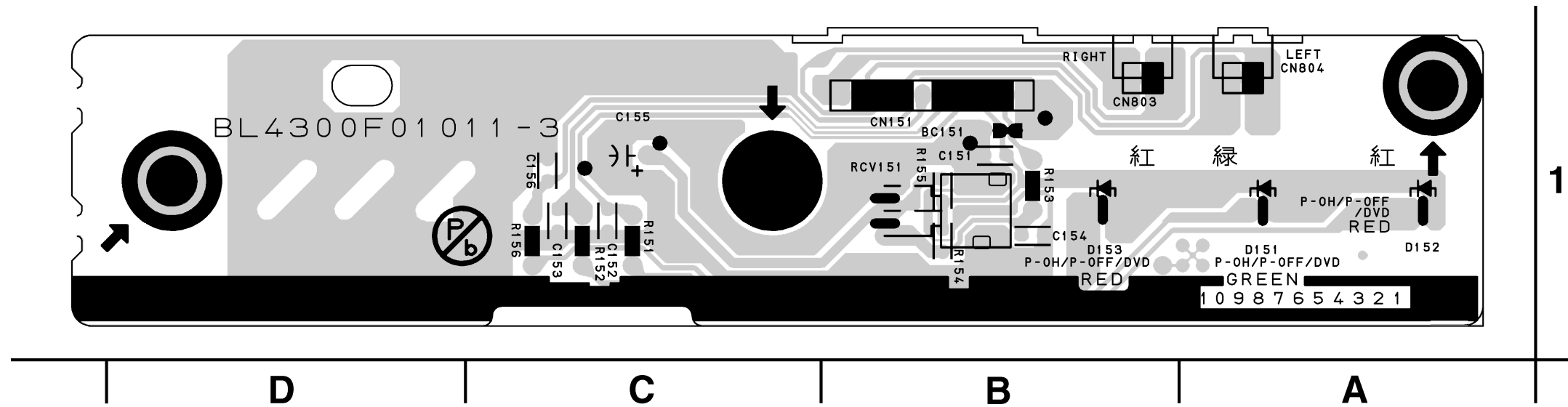




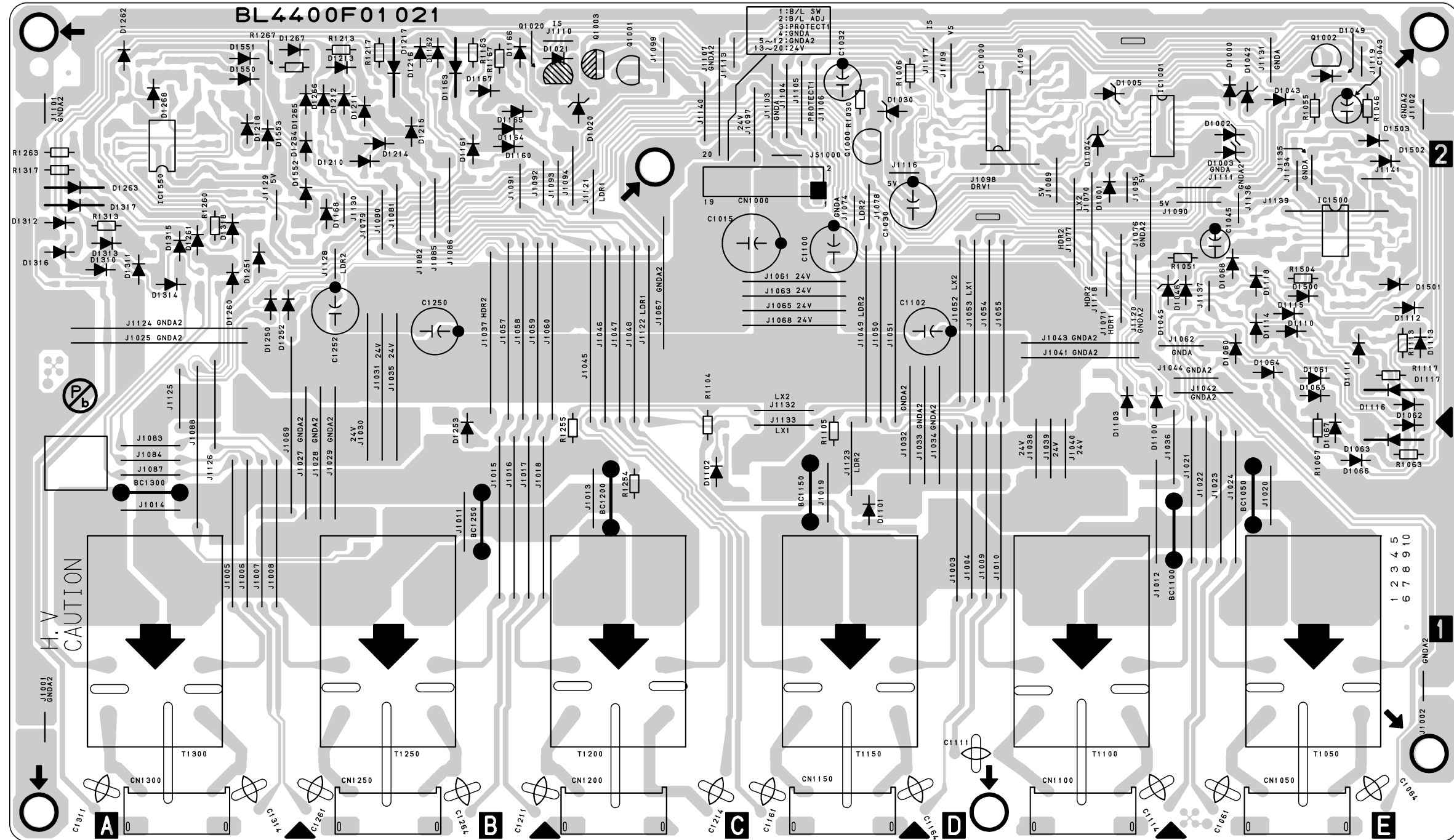
### LED CBA Top View



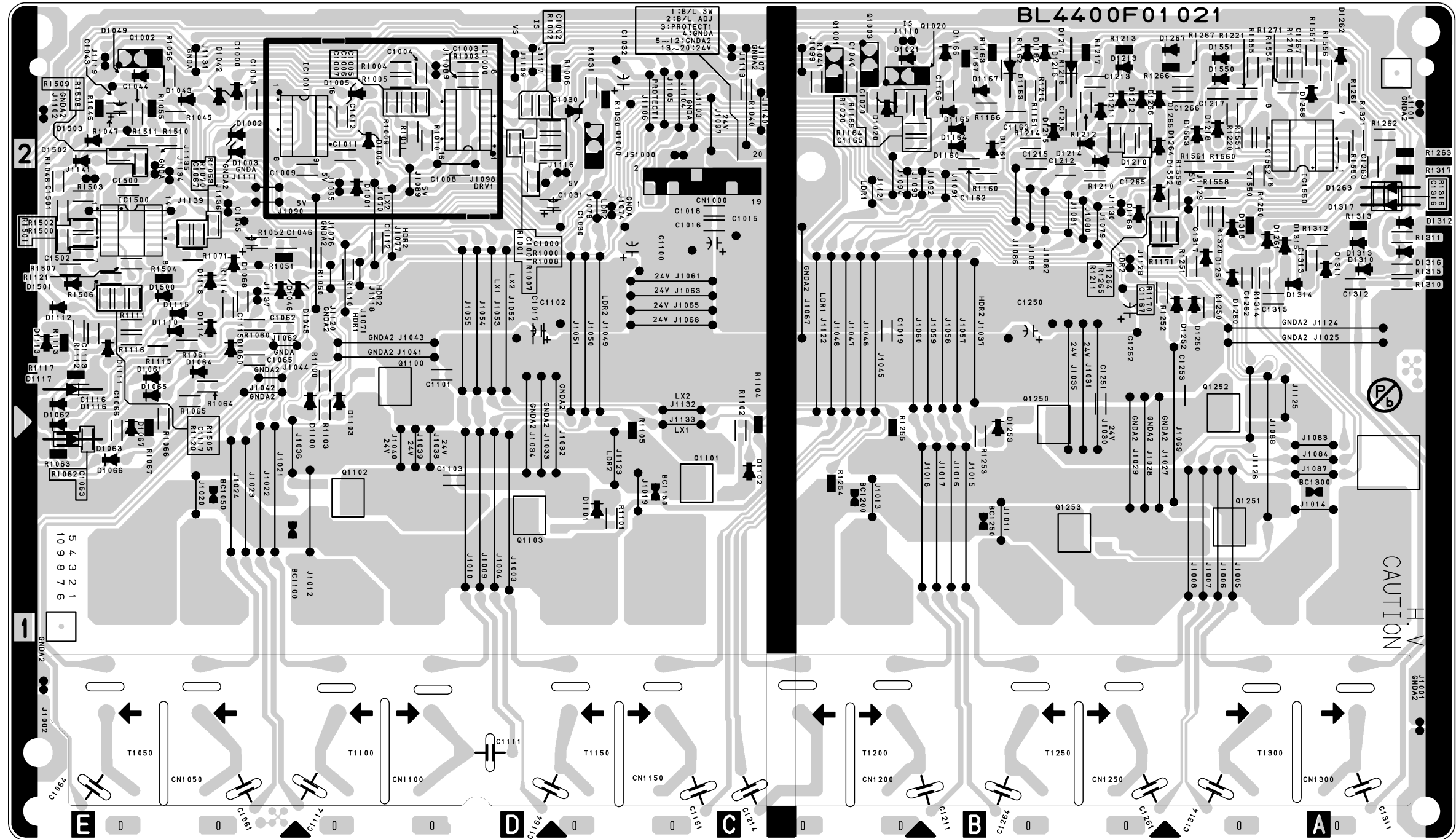
### LED CBA Bottom View



# Inverter CBA Top View



Inverter CBA Bottom View

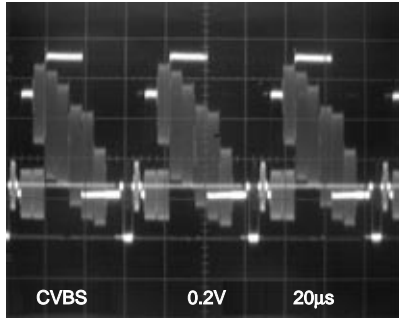


# WAVEFORMS

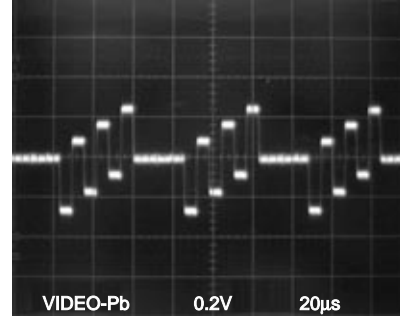
**WF1 ~ WF7 =** Waveforms to be observed at  
Waveform check points.  
(Shown in Schematic Diagram.)

**Input:** NTSC Color Bar Signal (with 1kHz Audio Signal)

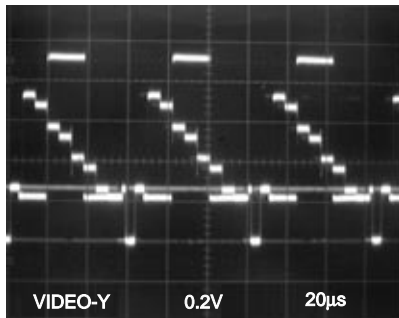
**WF1** Pin 2 of CN113



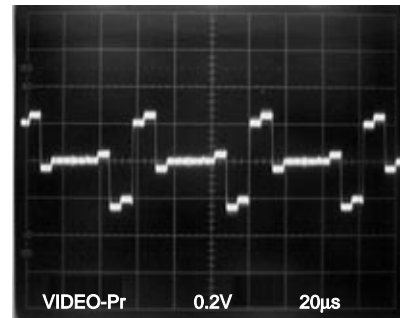
**WF5** Pin 13 of CN114



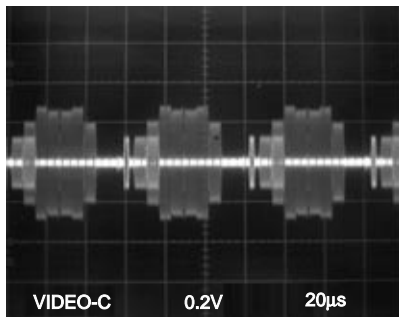
**WF2** Pin 21 of CN114



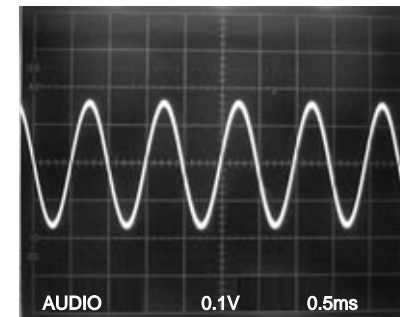
**WF6** Pin 14 of CN114



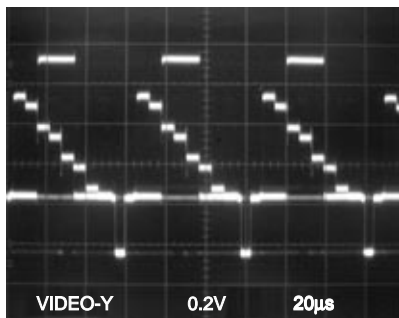
**WF3** Pin 22 of CN114



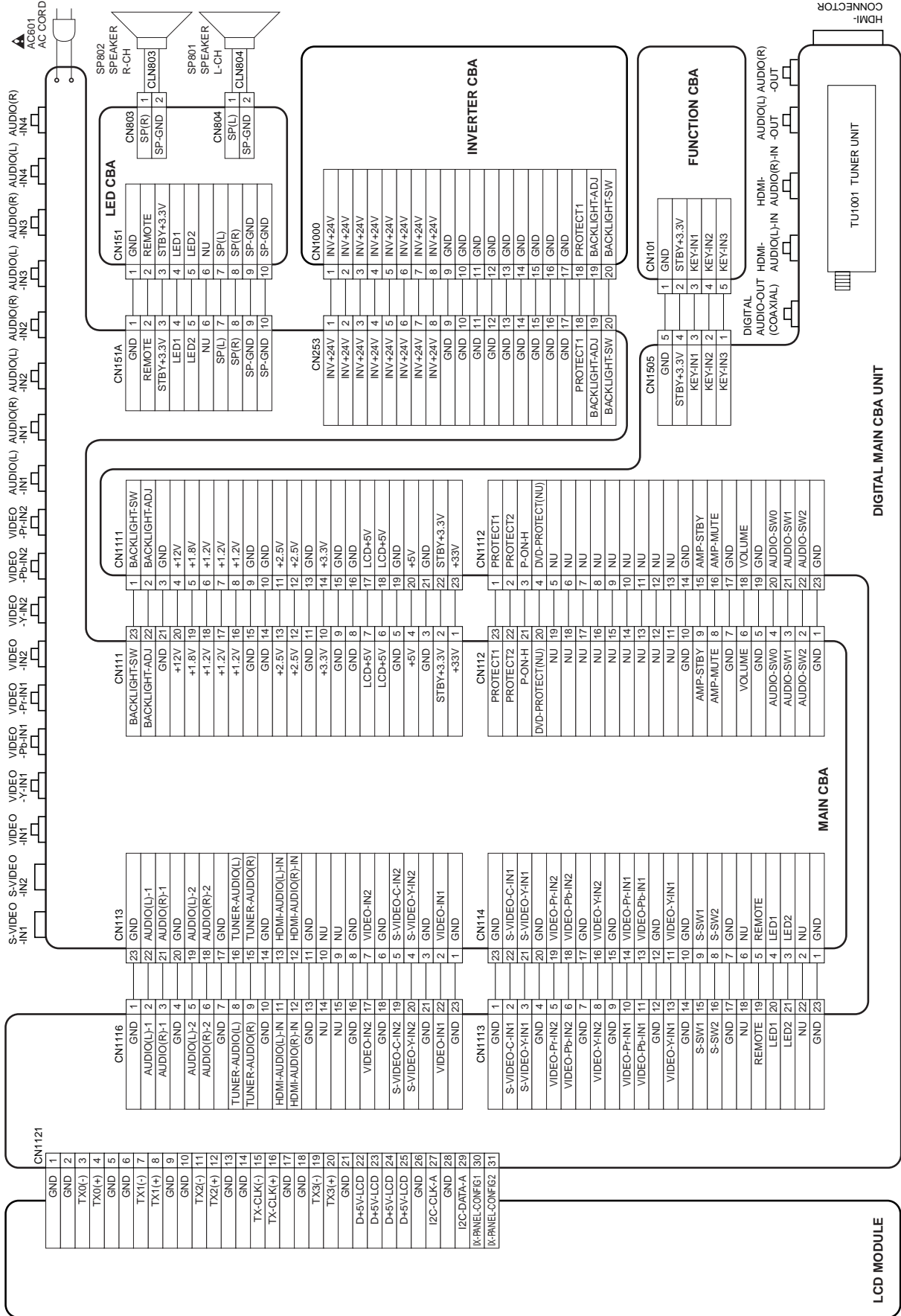
**WF7** Pin 8 of CN151A



**WF4** Pin 11 of CN114

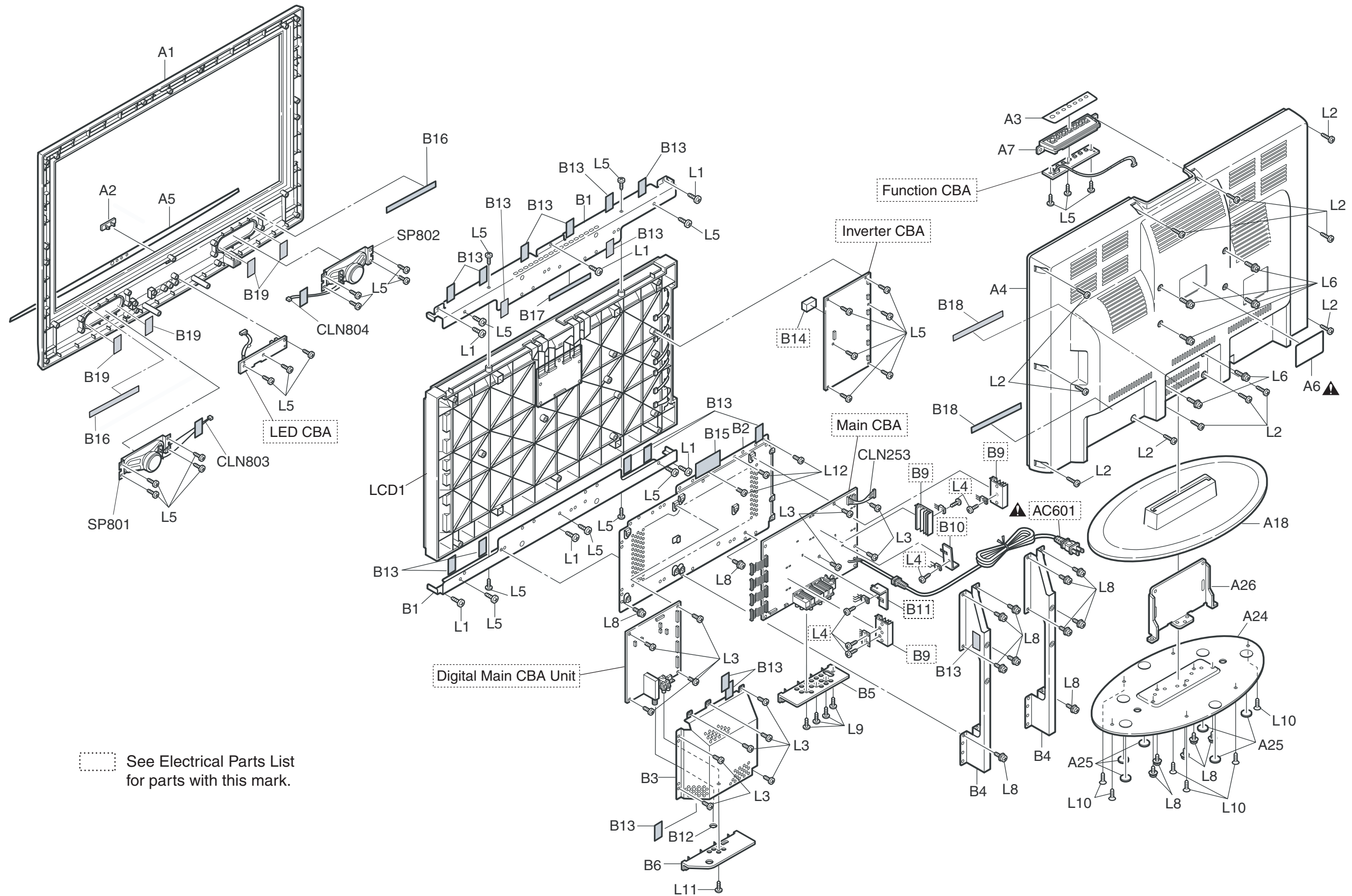


# WIRING DIAGRAM

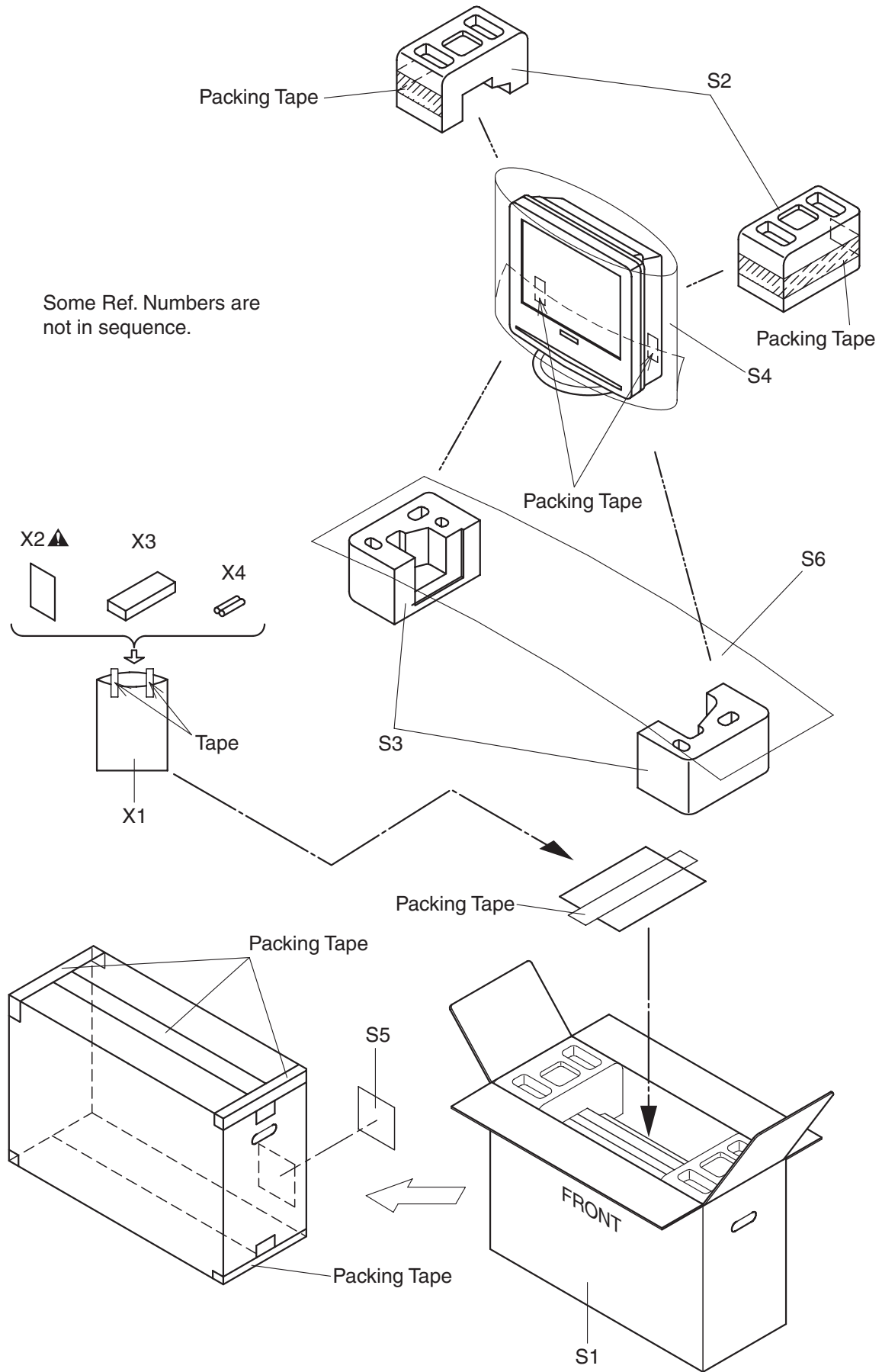


# EXPLODED VIEWS

## Cabinet




# Packing





# MECHANICAL PARTS LIST



**PRODUCT SAFETY NOTE:** Products marked with a  have special characteristics important to safety. Before replacing any of these components, read carefully the product safety notice in this service manual. Don't degrade the safety of the product through improper servicing.

**NOTE:** Parts that are not assigned part numbers (-----) are not available.

## Comparison Chart of Models and Marks


Model	Mark
6632LCT	A
6632LG	B

Ref. No.	Mark	Description	Part No.
A1	A	FRONT CABINET L4400UA	1EM020848A
A1	B	FRONT CABINET L4401UB	1EM021393A
A2		BRAND BADGE L T9000UA--SYLVANIA--	0EM409016
A3		CONTROL PLATE L4300UA	1EM321266
A4		REAR CABINET L4400UA	1EM020849
A5		DECORATION PLATE L4400UA	1EM121052
A6 	A	RATING LABEL L4400UA	-----
A6 	B	RATING LABEL L4401UB	-----
A7		FUNCTION KNOB L4300UA	1EM120992
A18	A	STAND COVER L4300UA	1EM020914
A18	B	STAND COVER L4301UB	1EM221344
A24		STAND BASE PLATE L4300UA	1EM121113
A25		STAND RUBBER FOOT L4300UA	1EM422534
A26		STAND HINGE L4300UA	1EM220784
B1		PANEL HOLDER L4400UA	1EM020850
B2		PCB HOLDER L4300UA	1EM120995
B3		SHIELD BOX L4300UA	1EM120996
B4		CHASSIS BRACKET L4300UA	1EM120993
B5		JACK HOLDER(A) L4300UA	1EM220681
B6		JACK HOLDER(D) L4300UA	1EM220682
B12		NUT 3/8-32UNEF	0EM401451A
B13		GRAND TAPE L4300UA	1EM423095
B15		GRAND TAPE L4400UA	1EM423347
B16		CLOTH(10X190XT0.3) L0200UA	1EM420019
B17		CLOTH(12X125XT 0.5) L0101JB	0EM408489
B18		CLOTH(10X180XT0.5) L0336JG	0EM408827
B19		CLOTH(20X65XT0.5) L0100JA	0EM407914
CLN253		WIRE ASSEMBLY 104 WX1L4400-104	WX1L4400-104
CLN803		WIRE ASSEMBLY 101 2PIN 210MM AWG24 RE	WX1L4300-101
CLN804		WIRE ASSEMBLY 101 2PIN 210MM AWG24 RE	WX1L4300-101
L1		SCREW P-TIGHT 4X14 BIND HEAD	GBJP4140
L2		SCREW P-TIGHT M4X14 PAN HEAD+BLK	GPHP4140
L3		SCREW S-TIGHT M3X6 BIND HEAD+	GBJS3060
L5		SCREW P-TIGHT 3X10 BIND HEAD+	GBJP3100
L6		DOUBLE SEMS SCREW M4X10 + BLK	FPH34100
L8		DOUBLE SEMS SCREW M4X6 M4X6	FPJ34060
L9		SCREW P-TIGHT 3X10 BIND HEAD+	GBHP3100
L10		SCREW P-TIGHT M3X12 DISH HEAD+	GDJP3120
L11		SCREW TAP TIGHT M3X10 BIND HEAD+BLK NI	GBHS3100
L12		SCREW P-TIGHT M3X8 BIND HEAD+	GBJP3080

Ref. No.	Mark	Description	Part No.
SP801		SPEAKER S0516F06	DSD0813XQ002
SP802		SPEAKER S0516F06	DSD0813XQ002
<b>PACKING</b>			
S1	A	CARTON L4400UA	1EM321391
S1	B	CARTON L4401UB	1EM322011
S2		STYROFOAM TOP L4400UA	1EM020875
S3		STYROFOAM BOTTOM L4400UA	1EM020876
S4		SET BAG L4300UA	1EM321546
S5		SERIAL NO. LABEL L9750UA	-----
S6		STAND SHEET L4300UA	1EM423161
<b>ACCESSORIES</b>			
X1		BAG POLYETHYLENE 235X365XT0.03	0EM408420A
X2 	A	OWNERS MANUAL L4400UA	1EMN21430A
X2 	B	OWNERS MANUAL L4401UB	1EMN21763
X3		REMOTE CONTROL NF000UD 170/ ECNLC401/NF000UD	NF000UD
X4		DRY BATTERY(SUNRISE) R6SSE/2S	XB0M451MS002



# ELECTRICAL PARTS LIST

**PRODUCT SAFETY NOTE:** Products marked with a  have special characteristics important to safety. Before replacing any of these components, read carefully the product safety notice in this service manual. Don't degrade the safety of the product through improper servicing.

**NOTES:**

- Parts that are not assigned part numbers (-----) are not available.
- Tolerance of Capacitors and Resistors are noted with the following symbols.

C.....±0.25%    D.....±0.5%    F.....±1%  
 G.....±2%    J.....±5%    K.....±10%  
 M.....±20%    N.....±30%    Z.....+80/-20%

## LCD MODULE ASSEMBLY

\*White Balance Adjustment and Flicker Adjustment are needed when repairing T-CON CBA.

Ref. No.	Description	Part No.
	LCD MODULE ASSEMBLY Consists of the following:	1FSA10108
	T-CON CBA CELL ACF ASSEMBLY BACKLIGHT ASSEMBLY	1FSA10109 ----- -----

## DIGITAL MAIN CBA UNIT

Ref. No.	Description	Part No.
	DIGITAL MAIN CBA UNIT	1ESA12816

## MMA CBA

Ref. No.	Description	Part No.
	MMA CBA Consists of the following:	1ESA12534
	MAIN CBA FUNCTION CBA LED CBA	----- ----- -----

## MAIN CBA

Ref. No.	Description	Part No.
	MAIN CBA Consists of the following:	-----
<b>CAPACITORS</b>		
C251	ELECTROLYTIC CAP. 100µF/10V M	CA1A101SP085
C252	CERAMIC CAP.(AX) F Z 0.01µF/25V	CDA1EZTOF103
C253	ELECTROLYTIC CAP.(47µF/50V) 50MA47HC+T	CA1J470SP085
C255	CHIP CERAMIC CAP. F Z 0.01µF/50V	CHD1JZ30F103
C402	ELECTROLYTIC CAP. 4.7µF/50V M	CA1J4R7SP085
C405	ELECTROLYTIC CAP. 4.7µF/50V M	CA1J4R7SP085
C408	ELECTROLYTIC CAP. 4.7µF/50V M	CA1J4R7SP085
C411	ELECTROLYTIC CAP. 4.7µF/50V M	CA1J4R7SP085
C415	ELECTROLYTIC CAP. 4.7µF/25V M	CA1E4R7SP085
C418	ELECTROLYTIC CAP. 4.7µF/25V M	CA1E4R7SP085
C421	ELECTROLYTIC CAP. 4.7µF/25V M	CA1E4R7SP085
C424	ELECTROLYTIC CAP. 4.7µF/25V M	CA1E4R7SP085

Ref. No.	Description	Part No.
C451	CHIP CERAMIC CAP.(1608) F Z 0.1µF/50V	CHD1JZ30F104
C452	ELECTROLYTIC CAP. 100µF/10V M	CA1A101SP085
C453	CHIP CERAMIC CAP.(1608) F Z 0.1µF/50V	CHD1JZ30F104
C454	ELECTROLYTIC CAP. 10µF/16V M	CA1C100SP085
C501	CERAMIC CAP. B K 1000pF/500V	CCD2JKP0B102
C503	ALUMINUM ELECTROLYTIC CAP 4700µF/35V M	CE1GMZNTM472
C504	ELECTROLYTIC CAP. 10µF/50V M	CA1J100SP085
C505	ALUMINUM ELECTROLYTIC CAP 1000µF/25V M	CE1EMZPTM102
C506	CERAMIC CAP.(AX) B K 0.01µF/50V	CA1J103TU011
C507	CHIP CERAMIC CAP. F Z 0.01µF/50V	CHD1JZ30F103
C508	ELECTROLYTIC CAP. 100µF/16V M	CA1C101SP085
C509	ALUMINUM ELECTROLYTIC CAP 2200µF/35V M	CE1GMZNTM222
C510	ELECTROLYTIC CAP. 470µF/16V M	CA1C471SP085
C511	ELECTROLYTIC CAP. 0.1µF/50V M	CE1JMASDL0R1
C531	CERAMIC CAP.(AX) B K 470pF/50V	CCA1JKT0B471
C532	ALUMINUM ELECTROLYTIC CAP 4700µF/6.3V M	CE0KMZNTM472
C533	CHIP CERAMIC CAP.(1608) F Z 0.01µF/25V	CHD1EZ30F103
C535	ELECTROLYTIC CAP. 10µF/50V M	CA1J100SP085
C536	ELECTROLYTIC CAP. 1000µF/6.3V M	CA0K102SP085
C537	ALUMINUM ELECTROLYTIC CAP 4700µF/10V M	CE1AMZNTM472
C538	FILM CAP.(P) 0.01µF/50V J	CA1J103MS029
C539	CERAMIC CAP.(AX) B K 0.047µF/50V	CA1J473TU011
C540	ALUMINUM ELECTROLYTIC CAP 1000µF/25V M	CE1EMZPTM102
C541	ELECTROLYTIC CAP. 1000µF/6.3V M	CA0K102SP085
C542	ALUMINUM ELECTROLYTIC CAP 1000µF/35V M	CE1GMZNTM102
C543	ELECTROLYTIC CAP. 10µF/50V M	CA1J100SP085
C544	CERAMIC CAP.(AX) F Z 0.01µF/25V	CDA1EZTOF103
C545	CERAMIC CAP.(AX) B K 0.01µF/50V	CA1J103TU011
C546	CERAMIC CAP.(AX) B K 0.01µF/50V	CA1J103TU011
C547	ELECTROLYTIC CAP. 1000µF/6.3V M	CA0K102SP085
C548	CERAMIC CAP.(AX) F Z 0.01µF/25V	CDA1EZTOF103
C549	ELECTROLYTIC CAP. 470µF/6.3V M	CA0K471SP085
C553	ELECTROLYTIC CAP. 220µF/25V M	CA1E221SP085
C554	ELECTROLYTIC CAP. 100µF/10V M	CA1A101SP085
C555	ELECTROLYTIC CAP. 10µF/50V M	CA1J100SP085
C556	ELECTROLYTIC CAP. 10µF/50V M	CA1J100SP085
C557	CHIP CERAMIC CAP.(1608) B K 0.1µF/50V	CHD1JK30B104
C559	ELECTROLYTIC CAP. 100µF/10V M	CA1A101SP085
C560	ELECTROLYTIC CAP. 10µF/50V M	CA1J100SP085
C561	CHIP CERAMIC CAP.(1608) B K 0.1µF/50V	CHD1JK30B104
C562	ELECTROLYTIC CAP. 10µF/50V M	CA1J100SP085
C563	CHIP CERAMIC CAP.(1608) B K 0.1µF/50V	CHD1JK30B104
C564	CHIP CERAMIC CAP.(1608) B K 0.1µF/50V	CHD1JK30B104
C565	CHIP CERAMIC CAP.(1608) B K 0.1µF/50V	CHD1JK30B104
C566	CHIP CERAMIC CAP.(1608) B K 0.1µF/50V	CHD1JK30B104
C567	ELECTROLYTIC CAP. 1000µF/6.3V M	CA0K102SP085
C570	ELECTROLYTIC CAP. 1000µF/6.3V M	CA0K102SP085
C572	CERAMIC CAP.(AX) B K 1000pF/50V	CCA1JKT0B102
C573	CERAMIC CAP.(AX) F Z 0.01µF/25V	CDA1EZTOF103
C574	CHIP CERAMIC CAP. F Z 0.01µF/50V	CHD1JZ30F103
C575	CHIP CERAMIC CAP.(1608) B K 2700pF/50V	CHD1JK30B272
C601▲	FILM CAP.(MP) 0.22µF/275V K	CT2E224DC011
C602▲	FILM CAP.(MP) 0.22µF/275V K	CT2E224DC011
C604	CERAMIC CAP. B K 0.01µF/500V	CCD2JKP0B103
C605	CERAMIC CAP. B K 0.01µF/500V	CCD2JKP0B103

Ref. No.	Description	Part No.
C606▲	ALUMINUM ELECTROLYTIC CAP 470µF/200V M	CA2D471NC190
C609	CERAMIC CAP. BN 1000pF/2KV	CCD3DKA0B102
C610	FILM CAP.(P) 0.033µF/50V J	CA1J333MS029
C615	FILM CAP.(P) 0.068µF/50V J	CA1J683MS029
C633	FILM CAP.(P) 0.033µF/50V J	CA1J333MS029
C634	CERAMIC CAP. BN 680pF/2KV	CCD3DKA0B681
C639	FILM CAP.(P) 0.068µF/50V J	CA1J683MS029
C640	ALUMINUM ELECTROLYTIC CAP 150µF/200V M	CE2DMZNTM151
C641	CERAMIC CAP. B K 0.01µF/500V	CCD2JKP0B103
C642	CERAMIC CAP. B K 0.01µF/500V	CCD2JKP0B103
C691▲	SAFETY CAP. 3300pF/250V	CCG2EMPVY332
C692	SAFETY CAP. 3300pF/250V	CCG2EMPVY332
C701	CHIP CERAMIC CAP.(1608) CH J 100pF/50V	CHD1JJ3CH101
C702	ELECTROLYTIC CAP. 47µF/16V M	CA1C470SP085
C704	CHIP CERAMIC CAP. F Z 0.01µF/50V	CHD1JZ30F103
C705	CHIP CERAMIC CAP.(1608) CH J 100pF/50V	CHD1JJ3CH101
C706	ELECTROLYTIC CAP. 47µF/16V M	CA1C470SP085
C708	CHIP CERAMIC CAP. F Z 0.01µF/50V	CHD1JZ30F103
C709	CHIP CERAMIC CAP.(1608) CH J 100pF/50V	CHD1JJ3CH101
C710	ELECTROLYTIC CAP. 47µF/16V M	CA1C470SP085
C711	CHIP CERAMIC CAP. F Z 0.01µF/50V	CHD1JZ30F103
C712	ELECTROLYTIC CAP. 100µF/10V M	CA1A101SP085
C714	CHIP CERAMIC CAP.(1608) CH J 100pF/50V	CHD1JJ3CH101
C715	CERAMIC CAP.(AX) B K 1000pF/50V	CCA1JKT0B102
C716	CHIP CERAMIC CAP. F Z 0.01µF/50V	CHD1JZ30F103
C718	CHIP CERAMIC CAP.(1608) CH J 100pF/50V	CHD1JJ3CH101
C719	ELECTROLYTIC CAP. 47µF/16V M	CA1C470SP085
C720	CHIP CERAMIC CAP. F Z 0.01µF/50V	CHD1JZ30F103
C721	ELECTROLYTIC CAP. 100µF/10V M	CA1A101SP085
C723	CHIP CERAMIC CAP.(1608) CH J 100pF/50V	CHD1JJ3CH101
C724	CERAMIC CAP.(AX) B K 1000pF/50V	CCA1JKT0B102
C725	CHIP CERAMIC CAP. F Z 0.01µF/50V	CHD1JZ30F103
C727	ELECTROLYTIC CAP. 100µF/10V M	CA1A101SP085
C728	ELECTROLYTIC CAP. 100µF/10V M	CA1A101SP085
C729	CHIP CERAMIC CAP.(1608) CH J 33pF/50V	CHD1JJ3CH330
C730	ELECTROLYTIC CAP. 47µF/16V M	CA1C470SP085
C732	PCB JUMPER D0.6-P5.0	JW5.0T
C733	CHIP CERAMIC CAP.(1608) CH J 33pF/50V	CHD1JJ3CH330
C734	ELECTROLYTIC CAP. 47µF/16V M	CA1C470SP085
C736	PCB JUMPER D0.6-P5.0	JW5.0T
C737	CHIP CERAMIC CAP. F Z 0.01µF/50V	CHD1JZ30F103
C738	CHIP CERAMIC CAP.(1608) CH J 33pF/50V	CHD1JJ3CH330
C739	ELECTROLYTIC CAP. 47µF/16V M	CA1C470SP085
C741	CHIP CERAMIC CAP. F Z 0.01µF/50V	CHD1JZ30F103
C742	PCB JUMPER D0.6-P5.0	JW5.0T
C743	CHIP CERAMIC CAP.(1608) CH J 33pF/50V	CHD1JJ3CH330
C744	ELECTROLYTIC CAP. 47µF/16V M	CA1C470SP085
C746	PCB JUMPER D0.6-P5.0	JW5.0T
C747	CHIP CERAMIC CAP.(1608) CH J 33pF/50V	CHD1JJ3CH330
C748	ELECTROLYTIC CAP. 47µF/16V M	CA1C470SP085
C750	PCB JUMPER D0.6-P5.0	JW5.0T
C751	CHIP CERAMIC CAP.(1608) CH J 33pF/50V	CHD1JJ3CH330
C752	ELECTROLYTIC CAP. 47µF/16V M	CA1C470SP085
C754	PCB JUMPER D0.6-P5.0	JW5.0T
C801	ALUMINUM ELECTROLYTIC CAP 1000µF/35V M	CE1GMZPTM102
C802	ELECTROLYTIC CAP. 220µF/35V M	CA1G221SP085
C803	ELECTROLYTIC CAP. 220µF/35V M	CA1G221SP085
C804	FILM CAP.(P) 0.1µF/50V J	CA1J104MS029
C805	FILM CAP.(P) 0.1µF/50V J	CA1J104MS029
C807	ELECTROLYTIC CAP. 100µF/25V M	CA1E101SP085
C809	ELECTROLYTIC CAP. 3.3µF/50V M	CA1J3R3SP085

Ref. No.	Description	Part No.
C810	ELECTROLYTIC CAP. 10µF/50V M	CA1J100SP085
C811	ELECTROLYTIC CAP. 100µF/10V M	CA1A101SP085
C813	ELECTROLYTIC CAP 1µF/50V M	CA1J1R0SP085
C814	ELECTROLYTIC CAP 1µF/50V M	CA1J1R0SP085
<b>CONNECTORS</b>		
CN111	TWG CONNECTOR 23P TWG-P23P-A1	J3TWA23TG001
CN112	TWG CONNECTOR 23P TWG-P23P-A1	J3TWA23TG001
CN113	TWG CONNECTOR 23P TWG-P23P-A1	J3TWA23TG001
CN114	TWG CONNECTOR 23P TWG-P23P-A1	J3TWA23TG001
CN151A	BOARD IN WIRE 106 10PIN 150MM-AWG26	WX1L4300-106
CN253	PH CONNECTOR TOP 20P B20B-PHDS5-B(LF)(SN)	J3F5D20JG003
<b>DIODES</b>		
D251	SWITCHING DIODE 1SS133(T-F7)	QDTZ001SS133
D501	DIODE SCHOTTKY YG802C10R	QDQZYG802C10
D502	SCHOTTKY BARRIER DIODE ERB84-009	QD7Z000ERB84
D503	DIODE FR104-B	NDLZ000FR104
D504	IC SHUNT REGULATOR KIA431-AT/P	NSZBA0TJY036
D505	ZENER DIODE MTZJF-7712B	QDTB00MTZJ12
D507	SWITCHING DIODE 1SS133(T-F7)	QDTZ001SS133
D508	SWITCHING DIODE 1SS133(T-F7)	QDTZ001SS133
D509	DIODE 1ZC30(Q)	QDLZ001ZC30Q
D510	ZENER DIODE MTZJT-7727B	QDTB00MTZJ27
D531	DIODE SCHOTTKY 31DQ03L	QDLZ031DQ03L
D532	DIODE SCHOTTKY 31DQ03L	QDLZ031DQ03L
D533	SCHOTTKY BARRIER DIODE ERC81-006	QDQZERC81006
D534	SCHOTTKY BARRIER DIODE ERC81-004	QDPZERC81004
D536	RECTIFIER DIODE FR202-B/P	NDQZ000FR202
D537	DIODE FR104-B	NDLZ000FR104
D538	SWITCHING DIODE 1SS133(T-F7)	QDTZ001SS133
D539	ZENER DIODE MTZJF-776.8B	QDTB0MTZJ6R8
D540	DIODE 1ZC43(Q)	QDLZ001ZC43Q
D541	ZENER DIODE MTZJT-7733B	QDTB00MTZJ33
D542	IC SHUNT REGULATOR KIA431-AT/P	NSZBA0TJY036
D543	SWITCHING DIODE 1SS133(T-F7)	QDTZ001SS133
D544	SWITCHING DIODE 1SS133(T-F7)	QDTZ001SS133
D545	ZENER DIODE MTZJT-773.3B	QDTB0MTZJ3R3
D546	SWITCHING DIODE 1SS133(T-F7)	QDTZ001SS133
D547	SWITCHING DIODE 1SS133(T-F7)	QDTZ001SS133
D549	SWITCHING DIODE 1SS133(T-F7)	QDTZ001SS133
D551	SWITCHING DIODE 1SS133(T-F7)	QDTZ001SS133
D552	SWITCHING DIODE 1SS133(T-F7)	QDTZ001SS133
D553	ZENER DIODE MTZJF-7715B	QDTB00MTZJ15
D554	SWITCHING DIODE 1SS133(T-F7)	QDTZ001SS133
D555	SWITCHING DIODE 1SS133(T-F7)	QDTZ001SS133
D556	SWITCHING DIODE 1SS133(T-F7)	QDTZ001SS133
D557	SWITCHING DIODE 1SS133(T-F7)	QDTZ001SS133
D558	SWITCHING DIODE 1SS133(T-F7)	QDTZ001SS133
D559	SWITCHING DIODE 1SS133(T-F7)	QDTZ001SS133
D561	SWITCHING DIODE 1SS133(T-F7)	QDTZ001SS133
D563	RECTIFIER DIODE ERA22-02	QDPZ0ERA2202
D564	SWITCHING DIODE 1SS133(T-F7)	QDTZ001SS133
D566	SWITCHING DIODE 1SS133(T-F7)	QDTZ001SS133
D582	SWITCHING DIODE 1SS133(T-F7)	QDTZ001SS133
D583	SWITCHING DIODE 1SS133(T-F7)	QDTZ001SS133
D591	SWITCHING DIODE 1SS133(T-F7)	QDTZ001SS133
D592	SWITCHING DIODE 1SS133(T-F7)	QDTZ001SS133
D593	ZENER DIODE MTZJT-774.7B	QDTB0MTZJ4R7
D594	ZENER DIODE MTZJT-773.9B	QDTB0MTZJ3R9
D601▲	DIODE 1N5406	NDLZ001N5406
D602▲	DIODE 1N5406	NDLZ001N5406
D603▲	DIODE 1N5406	NDLZ001N5406
D604▲	DIODE 1N5406	NDLZ001N5406

Ref. No.	Description	Part No.
D607▲	ZENER DIODE MTZJT-7727B	QDTB00MTZJ27
D608	ZENER DIODE MTZJT-777.5B	QDTB00MTZJ7R5
D609	SWITCHING DIODE 1SS133(T-77)	QDTZ001SS133
D610	SWITCHING DIODE 1SS133(T-77)	QDTZ001SS133
D611▲	SWITCHING DIODE 1SS133(T-77)	QDTZ001SS133
D612▲	ZENER DIODE MTZJT-7718B	QDTB00MTZJ18
D632▲	ZENER DIODE MTZJT-7727B	QDTB00MTZJ27
D633	ZENER DIODE MTZJT-775.6B	QDTB00MTZJ5R6
D634	SWITCHING DIODE 1SS133(T-77)	QDTZ001SS133
D635	SWITCHING DIODE 1SS133(T-77)	QDTZ001SS133
D636▲	SWITCHING DIODE 1SS133(T-77)	QDTZ001SS133
D637▲	ZENER DIODE MTZJT-7718B	QDTB00MTZJ18
D638▲	DIODE 1N5397-B	NDLZ001N5397
D639▲	DIODE 1N5397-B	NDLZ001N5397
D640▲	DIODE 1N5397-B	NDLZ001N5397
D641▲	DIODE 1N5397-B	NDLZ001N5397
D707	SWITCHING DIODE 1SS133(T-77)	QDTZ001SS133
D708	SWITCHING DIODE 1SS133(T-77)	QDTZ001SS133
D709	SWITCHING DIODE 1SS133(T-77)	QDTZ001SS133
D710	SWITCHING DIODE 1SS133(T-77)	QDTZ001SS133
D801	PCB JUMPER D0.6-P5.0	JW5.0T
D802	PCB JUMPER D0.6-P5.0	JW5.0T
D803	ZENER DIODE MTZJT-7715B	QDTB00MTZJ15
D814	SWITCHING DIODE 1SS133(T-77)	QDTZ001SS133
D816	SWITCHING DIODE 1SS133(T-77)	QDTZ001SS133
D881	SWITCHING DIODE 1SS133(T-77)	QDTZ001SS133
ICS		
IC451	IC ANALOG MULTIPLEXER CD4051BNSR	NSZBA0TTY157
IC452	IC ANALOG MULTIPLEXER CD4051BNSR	NSZBA0TTY157
IC531	VOLTAGE REGULATOR PQ070XF01SZH	QSZBA0SSH054
IC532	REGULATOR IC(3.5V) PQ035ZN1HZPH	QSZBA0TSH078
IC533	REGULATOR PQ018EF01SZH	QSZBA0SSH075
IC534	IC VOLTAGE REGULATOR 5V KIA7805API/P	NSZBA0SJY041
IC535	IC LD1117V	NSZBA0SS046
IC536▲	REGULATOR PQ1CG2032FZH	QSZBA0SSH071
IC537	REGULATOR(PB FREE) PQ033EF01SZH	QSZBA0SSH060
IC601	PHOTOCOUPLER LTV-817C-F	NPEC0LTV817F
IC602	PHOTOCOUPLER LTV-817C-F	NPEC0LTV817F
IC631	PHOTOCOUPLER LTV-817C-F	NPEC0LTV817F
IC801	AUDIO POWER IC AN17805A	QSZBA0SMS007
COILS		
L501	PCB JUMPER D0.6-P5.0	JW5.0T
L532	POWER INDUCTOR RCR1616-470M	LLC470MSF009
L533	CHOKE COIL 47μH	LLBD00PKV022
L534	INDUCTOR 15μH-K-5FT	LLARKBSTU150
L601▲	FILTER LLBG00ZY2015	LLBG00ZY2015
L602▲	FILTER LLBG00ZY2015	LLBG00ZY2015
TRANSISTORS		
Q251	TRANSISTOR KTC3199-GR-AT/P	NQS4KTC3199P
Q252	TRANSISTOR KTC3199-GR-AT/P	NQS4KTC3199P
Q451	TRANSISTOR KTC3199-GR-AT/P	NQS4KTC3199P
Q452	TRANSISTOR KTC3199-GR-AT/P	NQS4KTC3199P
Q453	TRANSISTOR KTC3199-GR-AT/P	NQS4KTC3199P
Q501	TRANSISTOR(PB FREE) KTC2026-Y/P	NQEYKTC2026P
Q502	TRANSISTOR KTC3199-GR-AT/P	NQS4KTC3199P
Q503	TRANSISTOR KTC3199-GR-AT/P	NQS4KTC3199P
Q504	NPN TRANSISTOR KRC103M-AT/P	NQSZKRC103MP
Q531	TRANSISTOR KTA1267-GR-AT/P	NQS1KTA1267P
Q533	TRANSISTOR KTC3199-GR-AT/P	NQS4KTC3199P
Q534	TRANSISTOR KTC3199-GR-AT/P	NQS4KTC3199P
Q535	TRANSISTOR KTC3199-GR-AT/P	NQS4KTC3199P
Q536	TRANSISTOR KTA1267-GR-AT/P	NQS1KTA1267P

Ref. No.	Description	Part No.
Q537	TRANSISTOR KTC3199-GR-AT/P	NQS4KTC3199P
Q601▲	FET MOS 2SK3797(Q)	QFQZ02SK3797
Q602▲	TRANSISTOR 2SC2120-O(Te2 F T)	QQS02SC2120F
Q603	TRANSISTOR KTC3199-GR-AT/P	NQS4KTC3199P
Q631▲	MOS FET 2SK3563	QFWZ02SK3563
Q632▲	TRANSISTOR 2SC2120-O(Te2 F T)	QQS02SC2120F
Q701	TRANSISTOR KTC3199-GR-AT/P	NQS4KTC3199P
Q702	TRANSISTOR KTC3199-GR-AT/P	NQS4KTC3199P
Q703	TRANSISTOR KTC3199-GR-AT/P	NQS4KTC3199P
Q704	TRANSISTOR KTC3199-GR-AT/P	NQS4KTC3199P
Q705	TRANSISTOR KTC3199-GR-AT/P	NQS4KTC3199P
Q706	TRANSISTOR KTC3199-GR-AT/P	NQS4KTC3199P
Q707	TRANSISTOR KTC3199-GR-AT/P	NQS4KTC3199P
Q708	TRANSISTOR KTC3199-GR-AT/P	NQS4KTC3199P
Q709	TRANSISTOR KTC3199-GR-AT/P	NQS4KTC3199P
Q710	TRANSISTOR KTC3199-GR-AT/P	NQS4KTC3199P
Q711	TRANSISTOR KTC3199-GR-AT/P	NQS4KTC3199P
Q712	TRANSISTOR KTC3199-GR-AT/P	NQS4KTC3199P
Q801	TRANSISTOR 2SC2120-O(Te2 F T)	QQS02SC2120F
Q802	TRANSISTOR KTC3199-GR-AT/P	NQS4KTC3199P
Q803	TRANSISTOR 2SA1931(Q)	QQZZ2SA1931Q
Q804	TRANSISTOR KTC3199-GR-AT/P	NQS4KTC3199P
RESISTORS		
R251	CARBON RES. 1/4W J 22 Ω	RCX4JATZ0220
R254	CHIP RES.(1608) 1/10W 0 Ω	RRXAJR5Z0000
R257	CHIP RES. 1/10W J 4.7k Ω	RRXAJR5Z0472
R258	CHIP RES. 1/10W J 100 Ω	RRXAJR5Z0101
R259	CHIP RES. 1/10W J 470 Ω	RRXAJR5Z0471
R260	CHIP RES. 1/10W J 4.7k Ω	RRXAJR5Z0472
R261	CHIP RES. 1/10W J 4.7k Ω	RRXAJR5Z0472
R262	CHIP RES.(1608) 1/10W 0 Ω	RRXAJR5Z0000
R401	CHIP RES. 1/10W J 47k Ω	RRXAJR5Z0473
R402	CARBON RES. 1/4W J 5.6k Ω	RCX4JATZ0562
R403	CHIP RES. 1/10W J 5.6k Ω	RRXAJR5Z0562
R404	CHIP RES. 1/10W J 47k Ω	RRXAJR5Z0473
R405	CARBON RES. 1/4W J 5.6k Ω	RCX4JATZ0562
R406	CHIP RES. 1/10W J 5.6k Ω	RRXAJR5Z0562
R407	CHIP RES. 1/10W J 47k Ω	RRXAJR5Z0473
R408	CHIP RES. 1/10W J 5.6k Ω	RRXAJR5Z0562
R409	CHIP RES. 1/10W J 5.6k Ω	RRXAJR5Z0562
R410	CHIP RES. 1/10W J 47k Ω	RRXAJR5Z0473
R411	CHIP RES. 1/10W J 5.6k Ω	RRXAJR5Z0562
R412	CHIP RES. 1/10W J 5.6k Ω	RRXAJR5Z0562
R413	CHIP RES. 1/10W J 47k Ω	RRXAJR5Z0473
R414	CHIP RES. 1/10W J 5.6k Ω	RRXAJR5Z0562
R415	CHIP RES. 1/10W J 5.6k Ω	RRXAJR5Z0562
R416	CHIP RES. 1/10W J 47k Ω	RRXAJR5Z0473
R417	CHIP RES. 1/10W J 5.6k Ω	RRXAJR5Z0562
R418	CHIP RES. 1/10W J 5.6k Ω	RRXAJR5Z0562
R419	CHIP RES. 1/10W J 47k Ω	RRXAJR5Z0473
R420	CHIP RES. 1/10W J 5.6k Ω	RRXAJR5Z0562
R421	CHIP RES. 1/10W J 5.6k Ω	RRXAJR5Z0562
R422	CHIP RES. 1/10W J 47k Ω	RRXAJR5Z0473
R423	CHIP RES. 1/10W J 5.6k Ω	RRXAJR5Z0562
R424	CHIP RES. 1/10W J 5.6k Ω	RRXAJR5Z0562
R453	CHIP RES. 1/10W J 100k Ω	RRXAJR5Z0104
R454	CHIP RES. 1/10W J 100k Ω	RRXAJR5Z0104
R455	CHIP RES. 1/10W J 100k Ω	RRXAJR5Z0104
R456	CHIP RES. 1/10W J 100k Ω	RRXAJR5Z0104
R457	CHIP RES. 1/10W J 100k Ω	RRXAJR5Z0104
R458	CHIP RES. 1/10W J 100k Ω	RRXAJR5Z0104
R459	CHIP RES. 1/10W J 100 Ω	RRXAJR5Z0101

Ref. No.	Description	Part No.
R460	CHIP RES. 1/10W J 10k Ω	RRXAJR5Z0103
R461	CHIP RES. 1/10W J 100k Ω	RRXAJR5Z0104
R462	CHIP RES. 1/10W J 100k Ω	RRXAJR5Z0104
R463	CHIP RES. 1/10W J 100k Ω	RRXAJR5Z0104
R464	CHIP RES. 1/10W J 100k Ω	RRXAJR5Z0104
R465	CARBON RES. 1/4W J 100k Ω	RCX4JATZ0104
R466	CHIP RES. 1/10W J 100k Ω	RRXAJR5Z0104
R473	CHIP RES. 1/10W J 100k Ω	RRXAJR5Z0104
R474	CHIP RES. 1/10W J 100k Ω	RRXAJR5Z0104
R475	CHIP RES. 1/10W J 100k Ω	RRXAJR5Z0104
R476	CARBON RES. 1/4W J 100k Ω	RCX4JATZ0104
R477	CHIP RES. 1/10W J 100k Ω	RRXAJR5Z0104
R478	CHIP RES. 1/10W J 100k Ω	RRXAJR5Z0104
R479	CHIP RES. 1/10W J 100 Ω	RRXAJR5Z0101
R480	CHIP RES. 1/10W J 10k Ω	RRXAJR5Z0103
R481	CHIP RES. 1/10W J 100k Ω	RRXAJR5Z0104
R482	CHIP RES. 1/10W J 100k Ω	RRXAJR5Z0104
R483	CHIP RES. 1/10W J 100k Ω	RRXAJR5Z0104
R484	CHIP RES. 1/10W J 100k Ω	RRXAJR5Z0104
R485	CHIP RES. 1/10W J 100k Ω	RRXAJR5Z0104
R486	CHIP RES. 1/10W J 100k Ω	RRXAJR5Z0104
R488	PCB JUMPER D0.6-P5.0	JW5.0T
R491	CARBON RES. 1/4W J 10k Ω	RCX4JATZ0103
R492	CARBON RES. 1/4W J 10k Ω	RCX4JATZ0103
R493	CARBON RES. 1/4W J 10k Ω	RCX4JATZ0103
R494	CHIP RES. 1/10W J 22k Ω	RRXAJR5Z0223
R495	CHIP RES. 1/10W J 22k Ω	RRXAJR5Z0223
R496	CHIP RES. 1/10W J 22k Ω	RRXAJR5Z0223
R500	METAL OXIDE FILM RES. 1W J 1.2 Ω	RN011R2ZU001
R501	CHIP RES. 1/10W F 8.2k Ω	RRXAFR5H8201
R502	CHIP RES. 1/10W F 8.2k Ω	RRXAFR5H8201
R503	CHIP RES. 1/10W J 2.7k Ω	RRXAJR5Z0272
R506	PCB JUMPER D0.6-P5.0	JW5.0T
R507	CARBON RES. 1/4W J 1k Ω	RCX4JATZ0102
R508	CHIP RES. 1/10W F 22k Ω	RRXAFR5H2202
R509	CHIP RES. 1/10W F 15k Ω	RRXAFR5H1502
R510	CARBON RES. 1/4W J 820 Ω	RCX4JATZ0821
R511	CHIP RES. 1/10W J 22k Ω	RRXAJR5Z0223
R512	CHIP RES.(1608) 1/10W F 2.2k Ω	RRXAFR5Z2201
R513	CHIP RES. 1/10W J 5.6k Ω	RRXAJR5Z0562
R514	CHIP RES. 1/10W J 2.2k Ω	RRXAJR5Z0222
R515	CARBON RES. 1/4W J 1.5k Ω	RCX4JATZ0152
R516	CARBON RES. 1/4W J 100 Ω	RCX4JATZ0101
R517	CARBON RES. 1/4W J 2.7k Ω	RCX4JATZ0272
R518	CHIP RES. 1/10W J 10k Ω	RRXAJR5Z0103
R519	CHIP RES. 1/10W J 5.6k Ω	RRXAJR5Z0562
R520	CHIP RES. 1/10W J 3.3k Ω	RRXAJR5Z0332
R523	METAL RESISTOR 2W J 820 Ω	RN02821ZU001
R524	METAL RESISTOR 2W J 820 Ω	RN02821ZU001
R530	CHIP RES. 1/10W F 7.5k Ω	RRXAFR5Z7501
R531	CARBON RES. 1/4W G 5.1k Ω	RCX4GATZ0512
R532	CARBON RES. 1/4W J 10k Ω	RCX4JATZ0103
R533	CHIP RES. 1/10W F 6.8k Ω	RRXAFR5Z6801
R534	CHIP RES.(1608) 1/10W 0 Ω	RRXAJR5Z0000
R535	CHIP RES. 1/10W J 4.7k Ω	RRXAJR5Z0472
R536	CHIP RES. 1/10W F 1.1k Ω	RRXAFR5H1101
R537	CHIP RES. 1/10W F 1k Ω	RRXAFR5Z1001
R538	CARBON RES. 1/4W J 10k Ω	RCX4JATZ0103
R540	CHIP RES. 1/10W J 10k Ω	RRXAJR5Z0103
R541	CARBON RES. 1/4W G 1.6k Ω	RCX4GATZ0162
R543	METAL OXIDE FILM RES. 1W J 1k Ω	RN01102ZU001
R544	CARBON RES. 1/4W J 1k Ω	RCX4JATZ0102
R545	CARBON RES. 1/4W J 10k Ω	RCX4JATZ0103

Ref. No.	Description	Part No.
R546	CHIP RES. 1/10W J 1k Ω	RRXAJR5Z0102
R547	METAL OXIDE FILM RES. 2W J 0.1 Ω	RN02R10KE010
R548	CHIP RES. 1/10W J 100 Ω	RRXAJR5Z0101
R551	CHIP RES. 1/10W J 8.2k Ω	RRXAJR5Z0822
R555	CARBON RES. 1/4W J 560 Ω	RCX4JATZ0561
R556	CHIP RES. 1/10W J 22k Ω	RRXAJR5Z0223
R557	CARBON RES. 1/4W J 820 Ω	RCX4JATZ0821
R558	CHIP RES.(1608) 1/10W F 2.2k Ω	RRXAFR5Z2201
R561	CHIP RES. 1/10W F 680 Ω	RRXAFR5H6800
R562	CHIP RES. 1/10W F 220 Ω	RRXAFR5H2200
R563	CHIP RES. 1/10W J 22k Ω	RRXAJR5Z0223
R565	CARBON RES. 1/4W J 10k Ω	RCX4JATZ0103
R566	CHIP RES. 1/10W J 47k Ω	RRXAJR5Z0473
R567	CARBON RES. 1/4W J 1.5k Ω	RCX4JATZ0152
R568	CARBON RES. 1/4W J 1.5k Ω	RCX4JATZ0152
R569	PCB JUMPER D0.6-P5.0	JW5.0T
R570	CHIP RES. 1/10W J 4.7k Ω	RRXAJR5Z0472
R571	CHIP RES. 1/10W J 10k Ω	RRXAJR5Z0103
R573	CARBON RES. 1/4W J 10k Ω	RCX4JATZ0103
R574	PCB JUMPER D0.6-P5.0	JW5.0T
R575	CARBON RES. 1/4W J 220 Ω	RCX4JATZ0221
R576	CARBON RES. 1/4W J 47k Ω	RCX4JATZ0473
R577	CARBON RES. 1/4W J 1k Ω	RCX4JATZ0102
R583	CHIP RES. 1/10W J 22k Ω	RRXAJR5Z0223
R584	CHIP RES. 1/10W J 3.3k Ω	RRXAJR5Z0332
R585	CARBON RES. 1/4W J 10k Ω	RCX4JATZ0103
R586	CHIP RES. 1/10W J 3.3k Ω	RRXAJR5Z0332
R590	CARBON RES. 1/4W J 620 Ω	RCX4JATZ0621
R591	CARBON RES. 1/4W J 1k Ω	RCX4JATZ0102
R601▲	CARBON RES. 1/2W J 3.3M Ω	RCX2JZQ0335
R602▲	CEMENT RESISTOR 5W J 0.82 Ω	RW05R82PAK10
R603▲	CARBON RES. 1/4W J 390k Ω	RCX4JATZ0394
R604	CARBON RES. 1/4W J 390k Ω	RCX4JATZ0394
R605	PCB JUMPER D0.6-P5.0	JW5.0T
R606	CARBON RES. 1/4W J 390k Ω	RCX4JATZ0394
R607▲	CARBON RES. 1/4W J 560k Ω	RCX4JATZ0564
R608	CARBON RES. 1/4W J 560k Ω	RCX4JATZ0564
R609	CARBON RES. 1/4W J 560k Ω	RCX4JATZ0564
R611	PCB JUMPER D0.6-P5.0	JW5.0T
R612	CARBON RES. 1/4W J 390k Ω	RCX4JATZ0394
R613	CARBON RES. 1/4W J 270 Ω	RCX4JATZ0271
R614	CARBON RES. 1/4W J 220 Ω	RCX4JATZ0221
R615	PCB JUMPER D0.6-P5.0	JW5.0T
R617	CARBON RES. 1/4W J 1.5k Ω	RCX4JATZ0152
R618	CARBON RES. 1/4W J 180 Ω	RCX4JATZ0181
R620▲	METAL OXIDE FILM RES. 2W J 0.27 Ω	RN02R27ZU001
R621	CARBON RES. 1/4W J 150 Ω	RCX4JATZ0151
R622	CARBON RES. 1/4W J 2.2k Ω	RCX4JATZ0222
R631▲	CARBON RES. 1/4W J 390k Ω	RCX4JATZ0394
R632	CARBON RES. 1/4W J 390k Ω	RCX4JATZ0394
R633	CARBON RES. 1/4W J 390k Ω	RCX4JATZ0394
R634	CARBON RES. 1/4W J 390k Ω	RCX4JATZ0394
R636	CARBON RES. 1/4W J 270 Ω	RCX4JATZ0271
R637	CARBON RES. 1/4W J 220 Ω	RCX4JATZ0221
R639	CARBON RES. 1/4W J 820 Ω	RCX4JATZ0821
R641	CARBON RES. 1/4W J 56 Ω	RCX4JATZ0560
R642	CARBON RES. 1/4W J 2.2k Ω	RCX4JATZ0222
R643	CARBON RES. 1/4W J 150 Ω	RCX4JATZ0151
R644▲	METAL OXIDE FILM RES. 2W J 0.47 Ω	RN02R47ZU001
R646	CEMENT RESISTOR 3W K 1.2 Ω	RW031R2PAK10
R701	CARBON RES. 1/4W J 75 Ω	RCX4JATZ0750
R702	CHIP RES.(1608) 1/10W 0 Ω	RRXAJR5Z0000
R704	CHIP RES. 1/10W J 33k Ω	RRXAJR5Z0333

Ref. No.	Description	Part No.
R705	CHIP RES. 1/10W J 39k Ω	RRXAJR5Z0393
R706	CHIP RES. 1/10W J 390 Ω	RRXAJR5Z0391
R707	CHIP RES.(1608) 1/10W 0 Ω	RRXAJR5Z0000
R708	CHIP RES. 1/10W J 75 Ω	RRXAJR5Z0750
R709	CHIP RES.(1608) 1/10W 0 Ω	RRXAJR5Z0000
R711	CHIP RES. 1/10W J 33k Ω	RRXAJR5Z0333
R712	CHIP RES. 1/10W J 39k Ω	RRXAJR5Z0393
R713	CHIP RES. 1/10W J 390 Ω	RRXAJR5Z0391
R714	CHIP RES.(1608) 1/10W 0 Ω	RRXAJR5Z0000
R715	CHIP RES. 1/10W J 75 Ω	RRXAJR5Z0750
R716	CHIP RES.(1608) 1/10W 0 Ω	RRXAJR5Z0000
R718	CHIP RES. 1/10W J 33k Ω	RRXAJR5Z0333
R719	CHIP RES. 1/10W J 39k Ω	RRXAJR5Z0393
R720	CHIP RES. 1/10W J 390 Ω	RRXAJR5Z0391
R721	CHIP RES.(1608) 1/10W 0 Ω	RRXAJR5Z0000
R722	CARBON RES. 1/4W J 22 Ω	RCX4JATZ0220
R723	CHIP RES. 1/10W J 75 Ω	RRXAJR5Z0750
R724	CHIP RES.(1608) 1/10W 0 Ω	RRXAJR5Z0000
R726	CHIP RES. 1/10W J 33k Ω	RRXAJR5Z0333
R727	CHIP RES. 1/10W J 39k Ω	RRXAJR5Z0393
R728	CHIP RES. 1/10W J 390 Ω	RRXAJR5Z0391
R729	CHIP RES.(1608) 1/10W 0 Ω	RRXAJR5Z0000
R730	CHIP RES. 1/10W J 75 Ω	RRXAJR5Z0750
R731	CHIP RES.(1608) 1/10W 0 Ω	RRXAJR5Z0000
R733	CHIP RES. 1/10W J 33k Ω	RRXAJR5Z0333
R734	CHIP RES. 1/10W J 39k Ω	RRXAJR5Z0393
R735	CHIP RES. 1/10W J 390 Ω	RRXAJR5Z0391
R736	CHIP RES.(1608) 1/10W 0 Ω	RRXAJR5Z0000
R737	CARBON RES. 1/4W J 22 Ω	RCX4JATZ0220
R738	CARBON RES. 1/4W J 75 Ω	RCX4JATZ0750
R739	PCB JUMPER D0.6-P5.0	JW5.0T
R741	CHIP RES. 1/10W J 33k Ω	RRXAJR5Z0333
R742	CHIP RES. 1/10W J 39k Ω	RRXAJR5Z0393
R743	CHIP RES. 1/10W J 390 Ω	RRXAJR5Z0391
R744	PCB JUMPER D0.6-P5.0	JW5.0T
R745	CARBON RES. 1/4W J 22 Ω	RCX4JATZ0220
R746	CARBON RES. 1/4W J 22 Ω	RCX4JATZ0220
R747	CHIP RES. 1/10W F 75 Ω	RRXAFFR5Z75R0
R748	CHIP RES.(1608) 1/10W 0 Ω	RRXAJR5Z0000
R751	CHIP RES. 1/10W J 33k Ω	RRXAJR5Z0333
R752	CHIP RES. 1/10W J 39k Ω	RRXAJR5Z0393
R753	CHIP RES. 1/10W J 390 Ω	RRXAJR5Z0391
R754	CHIP RES.(1608) 1/10W 0 Ω	RRXAJR5Z0000
R755	CHIP RES. 1/10W F 75 Ω	RRXAFFR5Z75R0
R756	PCB JUMPER D0.6-P5.0	JW5.0T
R759	CHIP RES. 1/10W J 33k Ω	RRXAJR5Z0333
R760	CHIP RES. 1/10W J 39k Ω	RRXAJR5Z0393
R761	CHIP RES. 1/10W J 390 Ω	RRXAJR5Z0391
R762	CHIP RES.(1608) 1/10W 0 Ω	RRXAJR5Z0000
R763	CHIP RES. 1/10W F 75 Ω	RRXAFFR5Z75R0
R764	CHIP RES.(1608) 1/10W 0 Ω	RRXAJR5Z0000
R767	CHIP RES. 1/10W J 33k Ω	RRXAJR5Z0333
R768	CHIP RES. 1/10W J 39k Ω	RRXAJR5Z0393
R769	CHIP RES. 1/10W J 390 Ω	RRXAJR5Z0391
R770	CHIP RES.(1608) 1/10W 0 Ω	RRXAJR5Z0000
R771	CHIP RES. 1/10W F 75 Ω	RRXAFFR5Z75R0
R772	PCB JUMPER D0.6-P5.0	JW5.0T
R775	CHIP RES. 1/10W J 33k Ω	RRXAJR5Z0333
R776	CHIP RES. 1/10W J 39k Ω	RRXAJR5Z0393
R777	CHIP RES. 1/10W J 390 Ω	RRXAJR5Z0391
R778	CHIP RES.(1608) 1/10W 0 Ω	RRXAJR5Z0000
R779	CHIP RES. 1/10W F 75 Ω	RRXAFFR5Z75R0
R780	CHIP RES.(1608) 1/10W 0 Ω	RRXAJR5Z0000

Ref. No.	Description	Part No.
R783	CHIP RES. 1/10W J 33k Ω	RRXAJR5Z0333
R784	CHIP RES. 1/10W J 39k Ω	RRXAJR5Z0393
R785	CHIP RES. 1/10W J 390 Ω	RRXAJR5Z0391
R786	CHIP RES.(1608) 1/10W 0 Ω	RRXAJR5Z0000
R787	CHIP RES. 1/10W F 75 Ω	RRXAFFR5Z75R0
R788	CHIP RES.(1608) 1/10W 0 Ω	RRXAJR5Z0000
R791	CHIP RES. 1/10W J 33k Ω	RRXAJR5Z0333
R792	CHIP RES. 1/10W J 39k Ω	RRXAJR5Z0393
R793	CHIP RES. 1/10W J 390 Ω	RRXAJR5Z0391
R794	PCB JUMPER D0.6-P5.0	JW5.0T
R801	METAL OXIDE FILM RES. 2W J 0.33 Ω	RN02R33ZU001
R803	CARBON RES. 1/4W J 100 Ω	RCX4JATZ0101
R804	CARBON RES. 1/4W J 10k Ω	RCX4JATZ0103
R807	CARBON RES. 1/4W J 10k Ω	RCX4JATZ0103
R808	CARBON RES. 1/4W J 100 Ω	RCX4JATZ0101
R809	CARBON RES. 1/4W J 2.7k Ω	RCX4JATZ0272
R810	PCB JUMPER D0.6-P5.0	JW5.0T
R811	CARBON RES. 1/4W J 100 Ω	RCX4JATZ0101
R812	CARBON RES. 1/4W J 100 Ω	RCX4JATZ0101
R813	PCB JUMPER D0.6-P5.0	JW5.0T
R815	CARBON RES. 1/4W J 10k Ω	RCX4JATZ0103
R816	CARBON RES. 1/4W J 4.7k Ω	RCX4JATZ0472
R817	METAL OXIDE FILM RES. 2W J 560 Ω	RN02561KE010
R823	PCB JUMPER D0.6-P5.0	JW5.0T
R824	CARBON RES. 1/4W J 1k Ω	RCX4JATZ0102
R825	CARBON RES. 1/4W J 390 Ω	RCX4JATZ0391
R826	CARBON RES. 1/4W J 2.2k Ω	RCX4JATZ0222
R827	CARBON RES. 1/4W J 2.2k Ω	RCX4JATZ0222
R828	CARBON RES. 1/4W J 390 Ω	RCX4JATZ0391
R829	CARBON RES. 1/4W J 4.7k Ω	RCX4JATZ0472
R830	CARBON RES. 1/4W J 1k Ω	RCX4JATZ0102
R831	CARBON RES. 1/4W J 10k Ω	RCX4JATZ0103
R881	CARBON RES. 1/4W J 15k Ω	RCX4JATZ0153
R882	CARBON RES. 1/4W J 2.2k Ω	RCX4JATZ0222
R927	CHIP RES.(1608) 1/10W 0 Ω	RRXAJR5Z0000
R931	CHIP RES. 1/10W J 10k Ω	RRXAJR5Z0103
<b>MISCELLANEOUS</b>		
AC601▲	AC CORD LP-11W&PT218P-K90A&S	WAC0172LW020
B9	HEAT SINK EAB ASSEMBLY L4300UA	1EM422612
B10	HEAT SINK PKH ASSEMBLY L3201UB	1EM420648
B11	HEAT SINK PLQ ASSEMBLY L4300UA	1EM422615
BC301	PCB JUMPER D0.6-P5.0	JW5.0T
BC302	PCB JUMPER D0.6-P5.0	JW5.0T
BC304	PCB JUMPER D0.6-P5.0	JW5.0T
BC501	BEAD INDUCTORS FBR07HA121TB-00	LLBF00ZTU021
BC502	BEAD INDUCTORS FBR07HA121TB-00	LLBF00ZTU021
BC503	BEAD INDUCTORS FBR07HA121TB-00	LLBF00ZTU021
BC531	BEAD INDUCTORS FBR07HA121TB-00	LLBF00ZTU021
BC532	BEAD INDUCTORS FBR07HA121TB-00	LLBF00ZTU021
BC601	BEAD INDUCTORS FBR07HA121TB-00	LLBF00ZTU021
BC602	BEAD INDUCTORS FBR07HA121TB-00	LLBF00ZTU021
BC631	BEAD INDUCTORS FBR07HA121TB-00	LLBF00ZTU021
BC632	BEAD INDUCTORS FBR07HA121TB-00	LLBF00ZTU021
F601▲	FUSE STC4A125V U/CT	LLBF00ZTU021
FC101	CLAMP FILTER ZCAT1325-0530A	XL03025TE001
FH601	FUSE HOLDER MSF-015	XH01Z00LY001
FH602	FUSE HOLDER MSF-015	XH01Z00LY001
GP691	GAP. FNR-G3.10D	FAZ000LD6005
JK701	6PIN JACK MSP-226V27-01 NI FE	JYRL060LY032
JK702	Y/C JACK(SW) YKF51-5563N	JYEL080JC002
JK703	5PIN JACK MSP-226V40-03 NI FE	JYRL050LY033
JK704	5PIN JACK MSP-226V40-03 NI FE	JYRL050LY033

Ref. No.	Description	Part No.
JS803	PCB JUMPER D0.6-P5.0	JW5.0T
L4	SCREW B-TIGHT D3X8 BIND HEAD+	GBJB3080
SA601▲	SURGE ABSORBER 470V+-10PER	NVQZ10D471KB
T601▲	SW TRANS 6706	LTT4PC0KT001
T631▲	SW TRANS 5809	LTT2PC0KT004

## FUNCTION CBA

Ref. No.	Description	Part No.
	FUNCTION CBA Consists of the following:	-----
<b>CAPACITORS</b>		
C101	CHIP CERAMIC CAP.(1608) F Z 0.1μF/50V	CHD1JZ30F104
C102	CHIP CERAMIC CAP.(1608) F Z 0.1μF/50V	CHD1JZ30F104
C103	CHIP CERAMIC CAP.(1608) F Z 0.1μF/50V	CHD1JZ30F104
C104	CHIP CERAMIC CAP.(1608) F Z 0.1μF/50V	CHD1JZ30F104
<b>CONNECTOR</b>		
CN101	PH CONNECTOR SIDE 5P S5B-PH-K-S(LF)(SN)	J3PHC05JG030
<b>RESISTORS</b>		
R101	PCB JUMPER D0.6-P5.0	JW5.0T
R102	CHIP RES. 1/10W J 10k Ω	RRXAJR5Z0103
R103	CHIP RES. 1/10W J 10k Ω	RRXAJR5Z0103
R104	PCB JUMPER D0.6-P5.0	JW5.0T
R105	CHIP RES. 1/10W J 2.4k Ω	RRXAJR5Z0242
R106	CARBON RES. 1/4W J 4.3k Ω	RCX4JATZ0432
R107	CHIP RES. 1/10W J 8.2k Ω	RRXAJR5Z0822
R108	CHIP RES. 1/10W J 24k Ω	RRXAJR5Z0243
R110	CHIP RES. 1/10W J 8.2k Ω	RRXAJR5Z0822
R111	CHIP RES. 1/10W J 2.4k Ω	RRXAJR5Z0242
R112	CHIP RES. 1/10W J 4.3k Ω	RRXAJR5Z0432
R113	CHIP RES. 1/10W J 8.2k Ω	RRXAJR5Z0822
R114	CHIP RES. 1/10W J 24k Ω	RRXAJR5Z0243
R115	CHIP RES. 1/10W J 4.3k Ω	RRXAJR5Z0432
R116	PCB JUMPER D0.6-P5.0	JW5.0T
R117	CHIP RES. 1/10W J 2.4k Ω	RRXAJR5Z0242
R118	CHIP RES. 1/10W J 10k Ω	RRXAJR5Z0103
<b>SWITCHES</b>		
SW101	TACT SWITCH SKQSAB	SST0101AL038
SW102	TACT SWITCH SKQSAB	SST0101AL038
SW103	TACT SWITCH SKQSAB	SST0101AL038
SW104	TACT SWITCH SKQSAB	SST0101AL038
SW105	TACT SWITCH SKQSAB	SST0101AL038
SW114	TACT SWITCH SKQSAB	SST0101AL038
SW115	TACT SWITCH SKQSAB	SST0101AL038

## LED CBA

Ref. No.	Description	Part No.
	LED CBA Consists of the following:	-----
<b>CAPACITORS</b>		
C151	CHIP CERAMIC CAP.(1608) F Z 0.1μF/50V	CHD1JZ30F104
C152	CHIP CERAMIC CAP.(1608) F Z 0.1μF/50V	CHD1JZ30F104
C153	CHIP CERAMIC CAP.(1608) F Z 0.1μF/50V	CHD1JZ30F104
C154	CHIP CERAMIC CAP. F Z 0.01μF/50V	CHD1JZ30F103
C155	ELECTROLYTIC CAP. 47μF/10V M H7	CE1AMASSM470
<b>CONNECTORS</b>		
CN151	PH CONNECTOR SIDE 10PIN S10B-PH-K-S(LF)(SN)	J3PHC10JG030
CN803	PH CONNECTOR SIDE 2P S2B-PH-K-S(LF)(SN)	J3PHC02JG030
CN804	PH CONNECTOR SIDE 2P S2B-PH-K-S(LF)(SN)	J3PHC02JG030

Ref. No.	Description	Part No.
<b>DIODES</b>		
D151	LED 333GT/E	NPHZ00333GTE
D152	LED L-53HT	NP4Z000L53HT
<b>RESISTORS</b>		
R151	CARBON RES. 1/4W J 220 Ω	RCX4JATZ0221
R152	CARBON RES. 1/4W J 220 Ω	RCX4JATZ0221
R153	CARBON RES. 1/4W J 1k Ω	RCX4JATZ0102
R154	CHIP RES. 1/10W J 3.3k Ω	RRXAJR5Z0332
R155	CHIP RES. 1/10W J 100 Ω	RRXAJR5Z0101
<b>MISCELLANEOUS</b>		
BC151	PCB JUMPER D0.6-P5.0	JW5.0T
RCV151	PHOTO LINK MODULE KSM-712TH2E	USESJR5K044

## INVERTER CBA

Ref. No.	Description	Part No.
	INVERTER CBA Consists of the following:	1ESA12537
<b>CAPACITORS</b>		
C1000	CHIP CERAMIC CAP. B K 1000pF/50V	CHD1JKB0B102
C1001	CHIP CERAMIC CAP. F Z 2.2μF/10V	CHD1AZ30F225
C1002	CHIP CERAMIC CAP. B K 1000pF/50V	CHD1JKB0B102
C1003	CHIP CERAMIC CAP. B K 1000pF/50V	CHD1JKB0B102
C1004	CHIP CERAMIC CAP. B K 0.01μF/50V	CHD1JKB0B102
C1005	CHIP CERAMIC CAP.(1608) CH J 1000pF/50V	CHD1JJ3CH103
C1006	CHIP CERAMIC CAP. B K 0.047μF/50V	CHD1JKB0B473
C1007	CHIP CERAMIC CAP. CH J 330pF/50V	CHD1JJBCH331
C1008	CHIP CERAMIC CAP. F Z 2.2μF/10V	CHD1AZ30F225
C1009	CHIP CERAMIC CAP. F Z 1μF/10V	CHD1AZB0F105
C1010	CHIP CERAMIC CAP. F Z 1μF/10V	CHD1AZB0F105
C1011	CHIP CERAMIC CAP.(1608) B K 0.47μF/10V	CHD1AK30B474
C1012	CHIP CERAMIC CAP.(1608) B K 0.47μF/10V	CHD1AK30B474
C1015	ALUMINUM ELECTROLYTIC CAP 470μF/35V M	CE1GMZNTM471
C1016	CHIP CERAMIC CAP.(1608) B K 0.1μF/50V	CHD1JK30B104
C1017	CHIP CERAMIC CAP.(1608) B K 0.1μF/50V	CHD1JK30B104
C1018	CHIP CERAMIC CAP.(1608) B K 0.1μF/50V	CHD1JK30B104
C1019	CHIP CERAMIC CAP.(1608) B K 0.1μF/50V	CHD1JK30B104
C1020	CHIP CERAMIC CAP. B K 0.01μF/50V	CHD1JKB0B103
C1030	ELECTROLYTIC CAP. 330μF/16V M	CE1CMASDL331
C1031	CHIP CERAMIC CAP.(1608) B K 0.1μF/50V	CHD1JK30B104
C1032	ELECTROLYTIC CAP. 47μF/35V M	CE1GMASDL470
C1040	CHIP CERAMIC CAP. B K 1000pF/50V	CHD1JKB0B102
C1043	ELECTROLYTIC CAP. 2.2μF/50V M	CE1JMASDL2R2
C1044	CHIP CERAMIC CAP.(1608) B K 1μF/10V	CHD1AK30B105
C1045	ELECTROLYTIC CAP. 2.2μF/50V M	CE1JMASDL2R2
C1046	CHIP CERAMIC CAP.(1608) B K 1μF/10V	CHD1AK30B105
C1061	CERAMIC CAP. SL D 10pF/3KV	CCD3FDASL100
C1062	CHIP CERAMIC CAP. B K 1200pF/50V	CHD1JK30B122
C1063	CHIP CERAMIC CAP. B K 2200pF/50V	CHD1JKB0B222
C1064	CERAMIC CAP. SL D 10pF/3KV	CCD3FDASL100
C1065	CHIP CERAMIC CAP. B K 1200pF/50V	CHD1JK30B122
C1066	CHIP CERAMIC CAP. B K 2200pF/50V	CHD1JKB0B222
C1067	CHIP CERAMIC CAP. B K 0.01μF/50V	CHD1JKB0B103
C1100	ELECTROLYTIC CAP. 100μF/35V M	CE1GMASDL101
C1101	CHIP CERAMIC CAP.(1608) B K 0.1μF/50V	CHD1JK30B104
C1102	ELECTROLYTIC CAP. 100μF/35V M	CE1GMASDL101
C1103	CHIP CERAMIC CAP.(1608) B K 0.1μF/50V	CHD1JK30B104
C1111	CERAMIC CAP. SL D 10pF/3KV	CCD3FDASL100
C1112	CHIP CERAMIC CAP. B K 1200pF/50V	CHD1JK30B122
C1113	CHIP CERAMIC CAP. B K 2200pF/50V	CHD1JKB0B222
C1114	CERAMIC CAP. SL D 10pF/3KV	CCD3FDASL100
C1115	CHIP CERAMIC CAP. B K 1200pF/50V	CHD1JK30B122

Ref. No.	Description	Part No.
C1116	CHIP CERAMIC CAP. B K 2200pF/50V	CHD1JKB0B222
C1117	CHIP CERAMIC CAP. B K 0.01μF/50V	CHD1JKB0B103
C1161	CERAMIC CAP. SL D 10pF/3KV	CCD3FDASL100
C1162	CHIP CERAMIC CAP. B K 1200pF/50V	CHD1JK30B122
C1163	CHIP CERAMIC CAP. B K 2200pF/50V	CHD1JKB0B222
C1164	CERAMIC CAP. SL D 10pF/3KV	CCD3FDASL100
C1165	CHIP CERAMIC CAP. B K 1200pF/50V	CHD1JK30B122
C1166	CHIP CERAMIC CAP. B K 2200pF/50V	CHD1JKB0B222
C1167	CHIP CERAMIC CAP. B K 0.01μF/50V	CHD1JKB0B103
C1211	CERAMIC CAP. SL D 10pF/3KV	CCD3FDASL100
C1212	CHIP CERAMIC CAP. B K 1200pF/50V	CHD1JK30B122
C1213	CHIP CERAMIC CAP. B K 2200pF/50V	CHD1JKB0B222
C1214	CERAMIC CAP. SL D 10pF/3KV	CCD3FDASL100
C1215	CHIP CERAMIC CAP. B K 1200pF/50V	CHD1JK30B122
C1216	CHIP CERAMIC CAP. B K 2200pF/50V	CHD1JKB0B222
C1217	CHIP CERAMIC CAP. B K 0.01μF/50V	CHD1JKB0B103
C1250	ELECTROLYTIC CAP. 100μF/35V M	CE1GMASDL101
C1251	CHIP CERAMIC CAP.(1608) B K 0.1μF/50V	CHD1JK30B104
C1252	ELECTROLYTIC CAP. 100μF/35V M	CE1GMASDL101
C1253	CHIP CERAMIC CAP.(1608) B K 0.1μF/50V	CHD1JK30B104
C1261	CERAMIC CAP. SL D 10pF/3KV	CCD3FDASL100
C1262	CHIP CERAMIC CAP. B K 1200pF/50V	CHD1JK30B122
C1263	CHIP CERAMIC CAP. B K 2200pF/50V	CHD1JKB0B222
C1264	CERAMIC CAP. SL D 10pF/3KV	CCD3FDASL100
C1265	CHIP CERAMIC CAP. B K 1200pF/50V	CHD1JK30B122
C1266	CHIP CERAMIC CAP. B K 2200pF/50V	CHD1JKB0B222
C1267	CHIP CERAMIC CAP. B K 0.01μF/50V	CHD1JKB0B103
C1311	CERAMIC CAP. SL D 10pF/3KV	CCD3FDASL100
C1312	CHIP CERAMIC CAP. B K 1200pF/50V	CHD1JK30B122
C1313	CHIP CERAMIC CAP. B K 2200pF/50V	CHD1JKB0B222
C1314	CERAMIC CAP. SL D 10pF/3KV	CCD3FDASL100
C1315	CHIP CERAMIC CAP. B K 1200pF/50V	CHD1JK30B122
C1316	CHIP CERAMIC CAP. B K 2200pF/50V	CHD1JKB0B222
C1317	CHIP CERAMIC CAP. B K 0.01μF/50V	CHD1JKB0B103
C1500	CHIP CERAMIC CAP.(1608) B K 0.22μF/25V	CHD1EK30B224
C1501	CHIP CERAMIC CAP.(1608) B K 0.22μF/25V	CHD1EK30B224
C1502	CHIP CERAMIC CAP.(1608) B K 0.22μF/25V	CHD1EK30B224
C1550	CHIP CERAMIC CAP.(1608) B K 0.22μF/25V	CHD1EK30B224
C1552	CHIP CERAMIC CAP.(1608) B K 0.22μF/25V	CHD1EK30B224
<b>CONNECTORS</b>		
CN1000	PH CONNECTOR TOP 20P B20B-PHDSS-B(LF)(SN)	J3F5D20JG003
CN1050	CONNECTOR/JACK 1747386-1	JB17J02AP002
CN1100	CONNECTOR/JACK 1747386-1	JB17J02AP002
CN1150	CONNECTOR/JACK 1747386-1	JB17J02AP002
CN1200	CONNECTOR/JACK 1747386-1	JB17J02AP002
CN1250	CONNECTOR/JACK 1747386-1	JB17J02AP002
CN1300	CONNECTOR/JACK 1747386-1	JB17J02AP002
<b>DIODES</b>		
D1000	SWITCHING DIODE 1SS133(T-77)	QDTZ001SS133
D1001	SWITCHING DIODE 1SS133(T-77)	QDTZ001SS133
D1002	ZENER DIODE MTZJT-776.2B	QDTB0MTZJ6R2
D1003	ZENER DIODE MTZJT-776.2B	QDTB0MTZJ6R2
D1004	ZENER DIODE MTZJT-776.2B	QDTB0MTZJ6R2
D1005	ZENER DIODE MTZJT-776.2B	QDTB0MTZJ6R2
D1020	ZENER DIODE MTZJT-775.1B	QDTB0MTZJ5R1
D1021	SWITCHING DIODE 1SS133(T-77)	QDTZ001SS133
D1030	ZENER DIODE MTZJT-775.6B	QDTB0MTZJ5R6
D1042	ZENER DIODE MTZJT-7724B	QDTB00MTZJ24
D1043	SWITCHING DIODE 1SS133(T-77)	QDTZ001SS133
D1045	ZENER DIODE MTZJT-7724B	QDTB00MTZJ24
D1046	SWITCHING DIODE 1SS133(T-77)	QDTZ001SS133
D1049	SWITCHING DIODE 1SS133(T-77)	QDTZ001SS133

Ref. No.	Description	Part No.
D1060	SWITCHING DIODE 1SS133(T-77)	QDTZ001SS133
D1061	SWITCHING DIODE 1SS133(T-77)	QDTZ001SS133
D1062	SWITCHING DIODE 1SS133(T-77)	QDTZ001SS133
D1063	SCHOTTKY BARRIER DIODE ERA81-004Q	QDLZRA81004Q
D1064	SWITCHING DIODE 1SS133(T-77)	QDTZ001SS133
D1065	SWITCHING DIODE 1SS133(T-77)	QDTZ001SS133
D1066	SWITCHING DIODE 1SS133(T-77)	QDTZ001SS133
D1067	SWITCHING DIODE 1SS133(T-77)	QDTZ001SS133
D1068	SWITCHING DIODE 1SS133(T-77)	QDTZ001SS133
D1110	SWITCHING DIODE 1SS133(T-77)	QDTZ001SS133
D1111	SWITCHING DIODE 1SS133(T-77)	QDTZ001SS133
D1112	SWITCHING DIODE 1SS133(T-77)	QDTZ001SS133
D1113	SWITCHING DIODE 1SS133(T-77)	QDTZ001SS133
D1114	SWITCHING DIODE 1SS133(T-77)	QDTZ001SS133
D1115	SWITCHING DIODE 1SS133(T-77)	QDTZ001SS133
D1116	SWITCHING DIODE 1SS133(T-77)	QDTZ001SS133
D1117	SCHOTTKY BARRIER DIODE ERA81-004Q	QDLZRA81004Q
D1118	SWITCHING DIODE 1SS133(T-77)	QDTZ001SS133
D1160	SWITCHING DIODE 1SS133(T-77)	QDTZ001SS133
D1161	SWITCHING DIODE 1SS133(T-77)	QDTZ001SS133
D1162	SWITCHING DIODE 1SS133(T-77)	QDTZ001SS133
D1163	SCHOTTKY BARRIER DIODE ERA81-004Q	QDLZRA81004Q
D1164	SWITCHING DIODE 1SS133(T-77)	QDTZ001SS133
D1165	SWITCHING DIODE 1SS133(T-77)	QDTZ001SS133
D1166	SWITCHING DIODE 1SS133(T-77)	QDTZ001SS133
D1167	SWITCHING DIODE 1SS133(T-77)	QDTZ001SS133
D1168	SWITCHING DIODE 1SS133(T-77)	QDTZ001SS133
D1210	SWITCHING DIODE 1SS133(T-77)	QDTZ001SS133
D1211	SWITCHING DIODE 1SS133(T-77)	QDTZ001SS133
D1212	SWITCHING DIODE 1SS133(T-77)	QDTZ001SS133
D1213	SWITCHING DIODE 1SS133(T-77)	QDTZ001SS133
D1214	SWITCHING DIODE 1SS133(T-77)	QDTZ001SS133
D1215	SWITCHING DIODE 1SS133(T-77)	QDTZ001SS133
D1216	SWITCHING DIODE 1SS133(T-77)	QDTZ001SS133
D1217	SCHOTTKY BARRIER DIODE ERA81-004Q	QDLZRA81004Q
D1218	SWITCHING DIODE 1SS133(T-77)	QDTZ001SS133
D1260	SWITCHING DIODE 1SS133(T-77)	QDTZ001SS133
D1261	SWITCHING DIODE 1SS133(T-77)	QDTZ001SS133
D1262	SWITCHING DIODE 1SS133(T-77)	QDTZ001SS133
D1263	SCHOTTKY BARRIER DIODE ERA81-004Q	QDLZRA81004Q
D1264	SWITCHING DIODE 1SS133(T-77)	QDTZ001SS133
D1265	SWITCHING DIODE 1SS133(T-77)	QDTZ001SS133
D1266	SWITCHING DIODE 1SS133(T-77)	QDTZ001SS133
D1267	SWITCHING DIODE 1SS133(T-77)	QDTZ001SS133
D1268	SWITCHING DIODE 1SS133(T-77)	QDTZ001SS133
D1310	SWITCHING DIODE 1SS133(T-77)	QDTZ001SS133
D1311	SWITCHING DIODE 1SS133(T-77)	QDTZ001SS133
D1312	SWITCHING DIODE 1SS133(T-77)	QDTZ001SS133
D1313	SWITCHING DIODE 1SS133(T-77)	QDTZ001SS133
D1314	SWITCHING DIODE 1SS133(T-77)	QDTZ001SS133
D1315	SWITCHING DIODE 1SS133(T-77)	QDTZ001SS133
D1316	SWITCHING DIODE 1SS133(T-77)	QDTZ001SS133
D1317	SCHOTTKY BARRIER DIODE ERA81-004Q	QDLZRA81004Q
D1318	SWITCHING DIODE 1SS133(T-77)	QDTZ001SS133
D1500	SWITCHING DIODE 1SS133(T-77)	QDTZ001SS133
D1501	SWITCHING DIODE 1SS133(T-77)	QDTZ001SS133
D1502	SWITCHING DIODE 1SS133(T-77)	QDTZ001SS133
D1503	SWITCHING DIODE 1SS133(T-77)	QDTZ001SS133
D1550	SWITCHING DIODE 1SS133(T-77)	QDTZ001SS133
D1551	SWITCHING DIODE 1SS133(T-77)	QDTZ001SS133
D1552	SWITCHING DIODE 1SS133(T-77)	QDTZ001SS133
D1553	SWITCHING DIODE 1SS133(T-77)	QDTZ001SS133

Ref. No.	Description	Part No.
<b>ICS</b>		
IC1000	IC PWM CONTROLLER OZ9938GN	NSZBA0TTMC01
IC1001	IC MOSFET DRIVER OZ9982GN	NSZBA0TTMC02
IC1500	IC BA10324AF-E2	QSZBA0TRM032
IC1550	IC BA10324AF-E2	QSZBA0TRM032
<b>TRANSISTORS</b>		
Q1000	TRANSISTOR KTC3205(Y)	NQSY0KTC3205
Q1001	TRANSISTOR KTC3199-GR-AT/P	NQS4KTC3199P
Q1002	TRANSISTOR KTC3199-GR-AT/P	NQS4KTC3199P
Q1003	NPN TRANSISTOR KRC103M-AT/P	NQSZKRC103MP
Q1020	TRANSISTOR KTA1267-GR-AT/P	NQS1KTA1267P
Q1100	MOS FET 2SK2614	QF1Z2SK2614Q
Q1101	MOS FET 2SK2614	QF1Z2SK2614Q
Q1102	MOS FET 2SK2614	QF1Z2SK2614Q
Q1103	MOS FET 2SK2614	QF1Z2SK2614Q
Q1250	MOS FET 2SK2614	QF1Z2SK2614Q
Q1251	MOS FET 2SK2614	QF1Z2SK2614Q
Q1252	MOS FET 2SK2614	QF1Z2SK2614Q
Q1253	MOS FET 2SK2614	QF1Z2SK2614Q
<b>RESISTORS</b>		
R1000	CHIP RES. 1/10W J 20k Ω	RRXAJR5Z0203
R1001	CHIP RES. 1/10W J 10k Ω	RRXAJR5Z0103
R1002	CHIP RES. 1/10W J 5.1k Ω	RRXAJR5Z0512
R1003	CHIP RES. 1/10W J 1M Ω	RRXAJR5Z0105
R1004	CHIP RES. 1/10W J 10k Ω	RRXAJR5Z0103
R1005	CHIP RES. 1/10W F 160 k Ω	RRXAFR5H1603
R1006	CARBON RES. 1/4W J 10k Ω	RCX4JATZ0103
R1007	CHIP RES. 1/10W J 30k Ω	RRXAJR5Z0303
R1008	CHIP RES. 1/10W J 30k Ω	RRXAJR5Z0303
R1009	CHIP RES. 1/10W F 1M Ω	RRXAFR5H1004
R1010	CHIP RES. 1/10W F 130k Ω	RRXAFR5H1303
R1011	CHIP RES. 1/10W F 110 k Ω	RRXAFR5H1103
R1020	CHIP RES. 1/10W J 1M Ω	RRXAJR5Z0105
R1030	CARBON RES. 1/4W J 470 Ω	RCX4JATZ0471
R1031	CHIP RES. 1/10W J 4.7k Ω	RRXAJR5Z0472
R1040	CHIP RES. 1/10W J 4.7k Ω	RRXAJR5Z0472
R1041	CHIP RES. 1/10W J 10k Ω	RRXAJR5Z0103
R1045	CHIP RES. 1/10W J 47k Ω	RRXAJR5Z0473
R1046	CARBON RES. 1/4W J 6.8k Ω	RCX4JATZ0682
R1047	CHIP RES. 1/10W J 1M Ω	RRXAJR5Z0105
R1048	CHIP RES. 1/10W J 1k Ω	RRXAJR5Z0102
R1050	CHIP RES. 1/10W J 47k Ω	RRXAJR5Z0473
R1051	CARBON RES. 1/4W J 6.8k Ω	RCX4JATZ0682
R1052	CHIP RES. 1/10W J 1M Ω	RRXAJR5Z0105
R1053	CHIP RES. 1/10W J 1k Ω	RRXAJR5Z0102
R1055	CARBON RES. 1/4W J 2.2k Ω	RCX4JATZ0222
R1056	CHIP RES. 1/10W J 3.3k Ω	RRXAJR5Z0332
R1060	CHIP RES. 1/10W J 100k Ω	RRXAJR5Z0104
R1061	CHIP RES. 1/10W J 20k Ω	RRXAJR5Z0203
R1062	CHIP RES. 1/10W F 470 Ω	RRXAFB5H4700
R1063	CARBON RES. 1/4W J 10k Ω	RCX4JATZ0103
R1064	CHIP RES. 1/10W J 100k Ω	RRXAJR5Z0104
R1065	CHIP RES. 1/10W J 20k Ω	RRXAJR5Z0203
R1066	CHIP RES. 1/10W F 470 Ω	RRXAFB5H4700
R1067	CARBON RES. 1/4W J 10k Ω	RCX4JATZ0103
R1070	CHIP RES. 1/10W J 1M Ω	RRXAJR5Z0105
R1071	CHIP RES. 1/10W J 1k Ω	RRXAJR5Z0102
R1100	CHIP RES.(1608) 1/10W 0 Ω	RRXAZR5Z0000
R1101	CHIP RES.(1608) 1/10W 0 Ω	RRXAZR5Z0000
R1102	CHIP RES.(1608) 1/10W 0 Ω	RRXAZR5Z0000
R1103	CHIP RES.(1608) 1/10W 0 Ω	RRXAZR5Z0000
R1104	PCB JUMPER D0.6-P5.0	JW5.0T

Ref. No.	Description	Part No.
R1105	PCB JUMPER D0.6-P5.0	JW5.0T
R1110	CHIP RES. 1/10W J 100k Ω	RRXAJR5Z0104
R1111	CHIP RES. 1/10W J 20k Ω	RRXAJR5Z0203
R1112	CHIP RES. 1/10W F 470 Ω	RRXAFB5H4700
R1113	CARBON RES. 1/4W J 10k Ω	RCX4JATZ0103
R1114	CHIP RES. 1/10W J 100k Ω	RRXAJR5Z0104
R1115	CHIP RES. 1/10W J 20k Ω	RRXAJR5Z0203
R1116	CHIP RES. 1/10W F 470 Ω	RRXAFB5H4700
R1117	CARBON RES. 1/4W J 10k Ω	RCX4JATZ0103
R1120	CHIP RES. 1/10W J 1M Ω	RRXAJR5Z0105
R1121	CHIP RES. 1/10W J 1k Ω	RRXAJR5Z0102
R1160	CHIP RES. 1/10W J 100k Ω	RRXAJR5Z0104
R1161	CHIP RES. 1/10W J 20k Ω	RRXAJR5Z0203
R1162	CHIP RES. 1/10W F 470 Ω	RRXAFB5H4700
R1163	CARBON RES. 1/4W J 10k Ω	RCX4JATZ0103
R1164	CHIP RES. 1/10W J 100k Ω	RRXAJR5Z0104
R1165	CHIP RES. 1/10W J 20k Ω	RRXAJR5Z0203
R1166	CHIP RES. 1/10W F 470 Ω	RRXAFB5H4700
R1167	CARBON RES. 1/4W J 10k Ω	RCX4JATZ0103
R1170	CHIP RES. 1/10W J 1M Ω	RRXAJR5Z0105
R1171	CHIP RES. 1/10W J 1k Ω	RRXAJR5Z0102
R1210	CHIP RES. 1/10W J 100k Ω	RRXAJR5Z0104
R1211	CHIP RES. 1/10W J 20k Ω	RRXAJR5Z0203
R1212	CHIP RES. 1/10W F 470 Ω	RRXAFB5H4700
R1213	CARBON RES. 1/4W J 10k Ω	RCX4JATZ0103
R1214	CHIP RES. 1/10W J 100k Ω	RRXAJR5Z0104
R1215	CHIP RES. 1/10W J 20k Ω	RRXAJR5Z0203
R1216	CHIP RES. 1/10W F 470 Ω	RRXAFB5H4700
R1217	CARBON RES. 1/4W J 10k Ω	RCX4JATZ0103
R1220	CHIP RES. 1/10W J 1M Ω	RRXAJR5Z0105
R1221	CHIP RES. 1/10W J 1k Ω	RRXAJR5Z0102
R1250	CHIP RES. 1/10W J 33 Ω	RRXAJR5Z0330
R1251	CHIP RES. 1/10W J 33 Ω	RRXAJR5Z0330
R1252	CHIP RES. 1/10W J 33 Ω	RRXAJR5Z0330
R1253	CHIP RES. 1/10W J 33 Ω	RRXAJR5Z0330
R1254	PCB JUMPER D0.6-P5.0	JW5.0T
R1255	PCB JUMPER D0.6-P5.0	JW5.0T
R1260	CARBON RES. 1/4W J 100k Ω	RCX4JATZ0104
R1261	CHIP RES. 1/10W J 20k Ω	RRXAJR5Z0203
R1262	CHIP RES. 1/10W F 470 Ω	RRXAFB5H4700
R1263	CARBON RES. 1/4W J 10k Ω	RCX4JATZ0103
R1264	CHIP RES. 1/10W J 100k Ω	RRXAJR5Z0104
R1265	CHIP RES. 1/10W J 20k Ω	RRXAJR5Z0203
R1266	CHIP RES. 1/10W F 470 Ω	RRXAFB5H4700
R1267	CARBON RES. 1/4W J 10k Ω	RCX4JATZ0103
R1270	CHIP RES. 1/10W J 1M Ω	RRXAJR5Z0105
R1271	CHIP RES. 1/10W J 1k Ω	RRXAJR5Z0102
R1310	CHIP RES. 1/10W J 100k Ω	RRXAJR5Z0104
R1311	CHIP RES. 1/10W J 20k Ω	RRXAJR5Z0203
R1312	CHIP RES. 1/10W F 470 Ω	RRXAFB5H4700
R1313	CARBON RES. 1/4W J 10k Ω	RCX4JATZ0103
R1314	CHIP RES. 1/10W J 100k Ω	RRXAJR5Z0104
R1315	CHIP RES. 1/10W J 20k Ω	RRXAJR5Z0203
R1316	CHIP RES. 1/10W F 470 Ω	RRXAFB5H4700
R1317	CARBON RES. 1/4W J 10k Ω	RCX4JATZ0103
R1320	CHIP RES. 1/10W J 1M Ω	RRXAJR5Z0105
R1321	CHIP RES. 1/10W J 1k Ω	RRXAJR5Z0102
R1500	CHIP RES. 1/10W F 9.1k Ω	RRXAFR5H9101
R1501	CHIP RES. 1/10W F 1.0k Ω	RRXAFR5H1001
R1502	CHIP RES. 1/10W F 9.1k Ω	RRXAFR5H9101
R1503	CHIP RES. 1/10W F 1.0k Ω	RRXAFR5H1001
R1504	CARBON RES. 1/4W J 10k Ω	RCX4JATZ0103
R1505	CHIP RES. 1/10W J 10k Ω	RRXAJR5Z0103



Ref. No.	Description	Part No.
R1506	CHIP RES. 1/10W J 10k Ω	RRXAJR5Z0103
R1507	CHIP RES. 1/10W J 10k Ω	RRXAJR5Z0103
R1508	CHIP RES. 1/10W J 10k Ω	RRXAJR5Z0103
R1509	CHIP RES. 1/10W J 10k Ω	RRXAJR5Z0103
R1510	CHIP RES. 1/10W J 10k Ω	RRXAJR5Z0103
R1511	CHIP RES. 1/10W J 10k Ω	RRXAJR5Z0103
R1550	CHIP RES. 1/10W F 9.1k Ω	RRXAFR5H9101
R1551	CHIP RES. 1/10W F 1.0k Ω	RRXAFR5H1001
R1554	CHIP RES. 1/10W J 10k Ω	RRXAJR5Z0103
R1555	CHIP RES. 1/10W J 10k Ω	RRXAJR5Z0103
R1556	CHIP RES. 1/10W J 10k Ω	RRXAJR5Z0103
R1557	CHIP RES. 1/10W J 10k Ω	RRXAJR5Z0103
R1558	CHIP RES. 1/10W J 10k Ω	RRXAJR5Z0103
R1559	CHIP RES. 1/10W J 10k Ω	RRXAJR5Z0103
R1560	CHIP RES. 1/10W J 10k Ω	RRXAJR5Z0103
R1561	CHIP RES. 1/10W J 10k Ω	RRXAJR5Z0103
<b>MISCELLANEOUS</b>		
B14	SHIELD BOX BOTTOM L4400UA	1EM423172
BC1050	PCB JUMPER D0.6-P10.0	JW10.0T
BC1100	PCB JUMPER D0.6-P10.0	JW10.0T
BC1150	PCB JUMPER D0.6-P10.0	JW10.0T
BC1200	PCB JUMPER D0.6-P10.0	JW10.0T
BC1250	PCB JUMPER D0.6-P10.0	JW10.0T
BC1300	PCB JUMPER D0.6-P10.0	JW10.0T
JS1000	PCB JUMPER D0.6-P5.0	JW5.0T
T1050	INVERTER TRANS ETJV27ZJ23AC	LTZ2PC0MS001
T1100	INVERTER TRANS ETJV27ZJ23AC	LTZ2PC0MS001
T1150	INVERTER TRANS ETJV27ZJ23AC	LTZ2PC0MS001
T1200	INVERTER TRANS ETJV27ZJ23AC	LTZ2PC0MS001
T1250	INVERTER TRANS ETJV27ZJ23AC	LTZ2PC0MS001
T1300	INVERTER TRANS ETJV27ZJ23AC	LTZ2PC0MS001

